

V-fit



G-RC RECUMBENT MAGNETIC CYCLE

☎ **Call FREEPHONE 0800-3-101-202 for
CUSTOMER SUPPORT (UK ONLY)**

If anything is wrong with your order, or if you have any questions or queries relating to the assembly or operation of this product, please get in touch by e-mail (support@benysports.co.uk) or, by calling our FREEPHONE Number 0800-3-101-202 (for the UK)

or
+44 (0) 1535-637711 (outside the UK),
so we have the opportunity to resolve any problems

Contents

<i>Section</i>	<i>Page</i>
<i>General Information</i>	4
<i>Before You Start</i>	5
<i>Safety</i>	6
<i>Exercise Information</i>	7
<i>Assembly</i>	13
<i>Exercise Monitor Instructions</i> . .	22



Protect the environment by not disposing of this product with household waste.



General Information

Quality

This exercise product has been designed and manufactured to comply with the latest (BS EN 957) British and European Safety Standards.

Questions

Should you encounter any difficulty with the assembly, operation or use of your exercise product or if you think that you may have parts missing, please **DO NOT** return it to your retailer but contact us first for help and advice, asking for **CUSTOMER SUPPORT**, by any of the following means.

Tel:- 0800 3 101 202 or
+44 (0) 1535 637711

Email:- support@benysports.co.uk

Website: www.benysports.co.uk

CUSTOMER SUPPORT open from 9.00am to 5.00pm
from Monday to Friday

Beny Sports Co. UK Ltd.
Unit 8 Riparian Way,
The Crossings Business Park,
Cross Hills,
West Yorkshire.
BD20 7BW

Queries

If you do have any queries, please ensure that you have the following information ready for our Customer Support Staff:

YOUR NAME
YOUR ADDRESS
YOUR PHONE NUMBER
PRODUCT MAKE OR BRAND
PRODUCT MODEL
PRODUCT SERIAL NUMBER
DATE OF PURCHASE
NAME OF RETAILER
PART NUMBERS REQUIRED

Guarantee

This product is guaranteed for **DOMESTIC USE ONLY** for a period of **1 YEAR** from the original certified date of purchase. During this period we have the right to: -

- a). Provide parts for the purchaser to effect repair.
- b). Repair the product, returned to our warehouse (at the purchaser's cost).
- c). Replace the product if it is deemed (by us) to be economical to do so.

This guarantee does not cover wear and tear on upholstery or consumables.

This guarantee does not cover abuse, defects caused by storage or use outside those intended.

If you need to advise us of a defect with your product and in order for us to service any requirement for replacement parts or repairs, we may ask for proof of purchase. Failure to do so may result in any claim for replacement parts or repairs being refused.

This guarantee, (both given and implied) applies to the original purchaser only, is not transferable and will be invalidated if used outside of the above criteria.

This guarantee is valid only in the United Kingdom and Eire.

This does not affect your statutory rights as a consumer.

Customer Support

Tel:- 0800 3 101 202 or
+44 (0) 1535 637711

Email:- support@benysports.co.uk

Website: www.benysports.co.uk

CUSTOMER SUPPORT open from 9.00am to 5.00pm
from Monday to Friday

Beny Sports Co. UK Ltd.
Unit 8 Riparian Way,
The Crossings Business Park,
Cross Hills,
West Yorkshire.
BD20 7BW

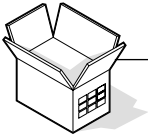

Before you Start

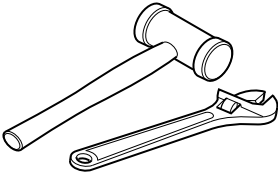

Tools

If required, most of our products are supplied with basic tools, which will enable you to successfully assemble your product. However, you may find it beneficial to have a soft-headed hammer and perhaps an adjustable spanner handy as this may help.

Prepare the Work Area

It is important that you assemble your product in a clean, clear, uncluttered area. This will enable you to move around the product while you are fitting components and will reduce the possibility of injury during assembly.

Work with a Friend

You may find it quicker, safer and easier to assemble this product with the help of a friend as some of the components may be large, heavy or awkward to handle alone.

Open the Carton.

Carefully open the carton that contains your product, taking note of the warnings printed on the carton to ensure that the risk of injury is reduced. Be aware of sharp staples that may be used to fasten the flaps as these may cause injury. Be sure to open the carton the right way up, as this will be the easiest and safest way to remove all the components.

Unpack the Components

Carefully unpack each component, checking against the parts list that you have all the necessary parts to complete the assembly of your product.

Please note that some of the parts may be pre-fitted to major components, so please check carefully before contacting our CUSTOMER SUPPORT team.

In any event, please do not return the product to your retailer before contacting us first.



Safety

Before you undertake any programme of exercise that will increase cardiovascular activity please be sure to consult with your doctor. Frequent strenuous exercise should be approved by your doctor and proper use of your product is essential. Please read this manual carefully before commencing assembly of your product or starting to exercise.

- * Please keep all children away from exercise products when in use. Do not allow children to climb or play on them when they are not in use. If children are allowed to use the equipment, their mental and physical development and above all their temperament should be taken into account. They should be controlled and instructed to the correct use of the equipment. The equipment is under no circumstances suitable as a children's toy.*
- * For your own safety, always ensure that there is at least 2 metres of free space in all directions around your product while you are exercising.*
- * Regularly check to see that all nuts, bolts and fittings are securely tightened. Periodically checking all moving parts for obvious signs of wear or damage.*
- * Clean only with a damp cloth, do not use solvent cleaners. If you are in any doubt, do not use your product, but contact CUSTOMER SUPPORT by any of the means listed on the opposite page.*
- * Before use, always ensure that your product is positioned on a solid, flat surface. If necessary, use a rubber mat underneath to reduce the possibility of slipping in use.*
- * Always wear appropriate clothing and footwear such as training shoes when exercising. Do not wear loose clothing that could become caught or trapped during exercise.*
- * Parents and others in charge of children should be aware of their responsibility because the natural play instinct and the fondness of experimenting of children can lead to situations and behavior for which the training equipment is not intended.*



Warning

If any part of your product becomes damaged, broken or badly worn do not use the equipment until the defective parts have been replaced

Storage and Use

Your product is intended for use in clean dry conditions. You should avoid storage in excessively cold or damp places as this may lead to corrosion and other related problems that are outside our control.

Weight Limit

*Your product is suitable for users weighing:
253 LBS / 18 Stones / 115 KG or less.*

Conformity

*This product conforms to:
BS EN ISO 20957-1 and BS EN 957-5
It is NOT suitable for therapeutic purposes.*



Exercising Information

Beginning

*How you begin to exercise will vary from person to person. If you have not exercised for a long period of time, have been inactive for a while, or are severely overweight you **MUST** start slowly, increasing your exercise time gradually, by perhaps only a few minutes for each session per week.*

Combine a carefully structured nutritious diet with a simple but effective exercise routine and this can help make you feel better, look better and will almost certainly enable you to enjoy life more.

Aerobic Fitness

Aerobic exercise is simply defined as any sustained activity that increases the supply of oxygen to your muscles via the blood pumped by your heart. With regular exercise, your cardiovascular system will become stronger and more efficient. Your recovery rate i.e. the time taken for your heart to reach its normal resting level, will also decrease.

Initially you may only be able to exercise for a few minutes each day. Do not hesitate to breathe through your mouth should you need more oxygen. Use the "talk test". If you cannot carry on a conversation while exercising, you are working too hard! However, aerobic fitness will be gradually built up with regular exercise, over the next six to eight weeks.

Do not be discouraged if it takes longer than this to begin to feel less lethargic, everyone is different and some will achieve their targets quicker than others. Work at your own, comfortable pace and the results will come. The better your aerobic fitness the harder you will have to work to stay in your target zone.



Exercising Information

Warm Up

A successful exercise programme consists of three parts, Warm Up, Aerobic Exercise and Cool Down. Never start a training session without warming up. Never finish one without cooling down correctly. Perform between five and ten minutes of stretching before starting your workout to prevent muscle strains, pulls and cramps.

Aerobic Exercise Session

Those new to exercise should exercise no more than every other day to start with.

As your fitness level increases, increase this to 2 in every 3 days.

When you are comfortable with your routine, exercise for 6 days per week. Always take at least one day off per week.



Note

Incorrect or excessive training may damage your health. Please read the exercise information first.

Exercising in your Target Zone

To ensure that your heart is working in its exercise target zone, you need to be able to take your pulse. If you do not have a pulse monitor (either from the product you are using or a proprietary independent unit) you will need to locate the pulse in your carotid artery. This is situated in the side of the neck and can be felt by using the index and middle fingers. Simply count the number of beats you feel in 10 seconds and then multiply by six to get your pulse rate. This should be taken before you start to exercise for easy reference.

People who have a greater aerobic fitness, have a lower resting pulse level and will also be able to exercise with a higher pulse level.

Target Zone

To determine your target zone, see the chart opposite. If you are new to exercise and by definition unfit, refer to the left column. If you exercise regularly and have good aerobic fitness, refer to the right column.



Exercising Information

Target Zone (con't)

USERS AGE	UNCONDITIONED TARGET ZONE - A	CONDITIONED TARGET ZONE - B
(Years)	(Beats per Minute)	(Beats per Minute)
20-24	145 - 165	155 - 175
25-29	140 - 160	150 - 170
30-34	135 - 155	145 - 165
35-39	130 - 150	140 - 160
40-44	125 - 145	135 - 155
45-49	120 - 140	130 - 150
50-54	115 - 135	125 - 145
55-59	110 - 130	120 - 140
60 and over	105 - 125	115 - 135

Cool Down

To decrease fatigue and muscle soreness, you should also cool down by walking at a slow relaxed pace for a minute or so, to allow your heart rate to return to normal.

Warm Up and Cool Down Exercises

Hold each stretch for a minimum of ten seconds and then relax. Repeat each stretch two or three times. Do this before your Aerobic Exercise session and also after you have finished.

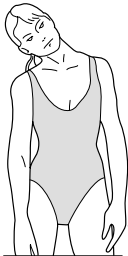

Head Roll

Rotate your head to the right for one count, feeling a slight pull on the left side of your neck. Next, rotate your head back for one count, stretching your chin. Then rotate your head to the left for one count, feeling a slight pull on the right side of your neck. Lastly, drop your head to your chest for one count. Repeat 2 to 3 times.

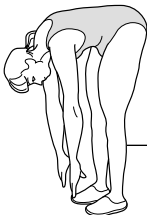

Toe Touch

Slowly bend forward from your waist, letting your back and shoulders relax as you lower your trunk. Gently stretch down as far as is comfortable and hold for 10 seconds.

Exercising Information



Shoulder Lift

Rotate and lift your right shoulder up towards your ear for one count. Relax then repeat for the left shoulder. Repeat 3 - 4 times.

Calf / Achilles Stretch

Turn towards the wall and place both hands on it. Support yourself with one leg while the other is placed behind you with the sole flat on the floor. Bend the front leg and lean towards the wall, keeping the rear leg straight so that the calf and Achilles tendon are stretched hold for 5 seconds. Repeat with the other leg. Repeat 2 - 3 times.

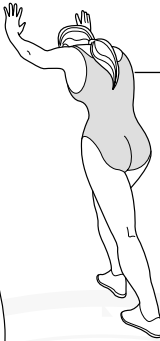

Side Stretch

Open both arms to the side and gently lift them above your head. Reach your right arm as high as you can for one count, gently stretching the muscles of the stomach and lower back. Repeat the action with your left arm. Repeat 3 - 4 times.

Inner Thigh Stretch

Sit on the floor and pull your legs toward your groin, the soles of your feet together. Hold your back straight and lean forward over your feet. Tighten the thigh muscles and hold for 5 seconds. Release and repeat 3 - 4 times.



Hamstring Stretch

Sit on the floor with your right leg extended and place your left foot flat against the right inner thigh. Stretch forward toward the right foot and hold for 10 seconds. Relax and then repeat with the left leg extended. Repeat 2 - 3 times.

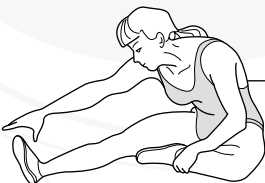



Exercising Information

Basic Aerobic Training Programme

For your basic Aerobic Exercise routine we suggest that you try the following. Remember, breathe correctly, exercise at your own pace and do not over-train as injury may result.

Week 1 & 2

Warm Up 5 - 10 Minutes
Cool Down 5 Minutes

Exercise 4 minutes at 'A'
Rest 1 minute
Exercise 2 minutes at 'A'
Exercise slowly 1 minute

Week 3 & 4

Warm Up 5 - 10 Minutes
Cool Down 5 Minutes

Exercise 5 minutes at 'A'
Rest 1 minute
Exercise 3 minutes at 'A'
Exercise slowly 2 minutes

Week 5 & 6

Warm Up 5 - 10 Minutes
Cool Down 5 Minutes

Exercise 6 minutes at 'A'
Rest 1 minute
Exercise 4 minutes at 'A'
Exercise slowly 3 minutes

Week 7 & 8

Warm Up 5 - 10 Minutes
Cool Down 5 Minutes

Exercise 5 minutes at 'A'
Exercise 3 minutes at 'B'
Exercise 2 minutes at 'A'
Exercise slowly 1 minute
Exercise 4 minutes at 'A'
Exercise slowly 3 minutes

Week 9 & beyond

Warm Up 5 - 10 Minutes
Cool Down 5 Minutes

Exercise 5 minutes at 'A'
Exercise 3 minutes at 'B'
Exercise 2 minutes at 'A'
Exercise slowly 1 minute
Repeat entire cycle 2 or 3 times

This is only a suggested programme and may not suit every individual's needs.



Exercising Information

GENERAL USER INFORMATION LEVELLING THE CROSS TRAINER



Note

In accordance with BS EN 957, the braking system on your Cycle is speed-independent.

For security and stability, your Manual Magnetic Cycle Trainer has a factory welded frame and once fully assembled correctly, should not need further alignment. However, in the interest of safety, please always ensure that your Cycle Trainer is positioned on a solid, flat surface. If necessary, use a rubber mat underneath to reduce the possibility of damaging flooring or slipping in use. If you need to make a fine adjustment, simply twist the end of either Rear Frame Stabiliser End Cap (37) to compensate for uneven floors.

RESISTANCE ADJUSTMENT



Note

The foot print for this product is 1350mm x 640mm.

To ensure smooth efficient cycling action, the magnetic braking system on your Magnetic Cycle Trainer has been correctly adjusted by our factory during production. To adjust the pedalling resistance during use, starting by turning the Tension Control Knob (54) to the position "1" from the beginning of your workout. Gradually increase the pedalling resistance by turning the Tension Control Knob as required. When you have finished your routine, turn the Tension Control Knob to the position "8" again to ensure that the Tension Control Cable is not under tension when your Magnetic Cycle Trainer not in use.

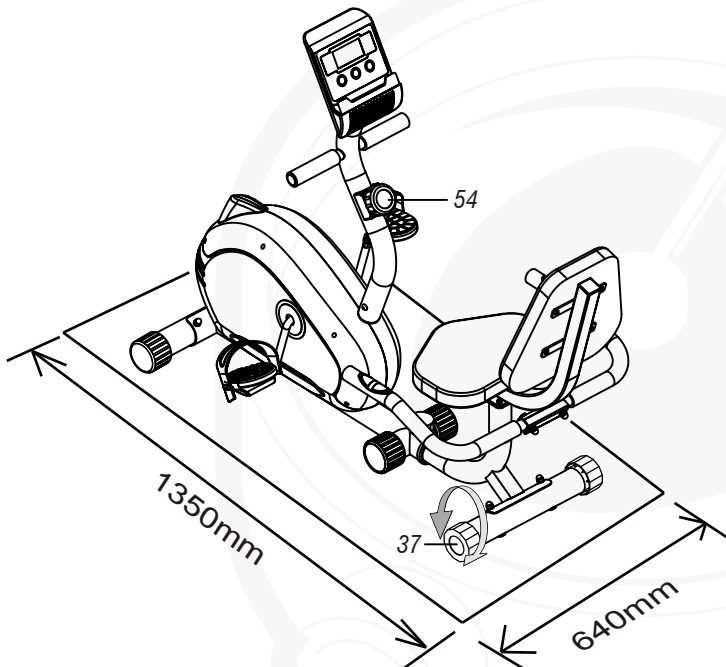

Assembly



ACCESSORY FITMENT LIST

These are all the accessories you will need to complete the assembly of your product.

The following accessories are supplied in a pack and should be checked before attempting assembly.

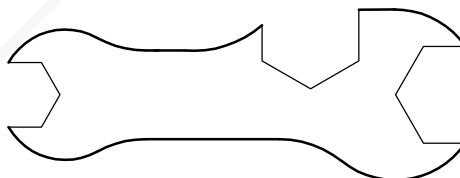
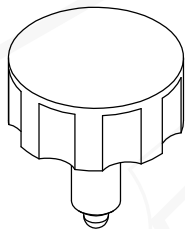
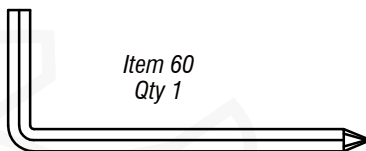
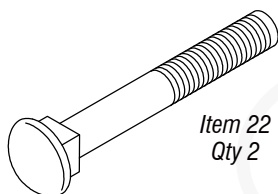
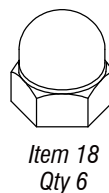
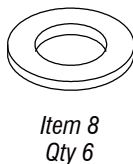
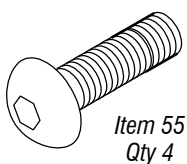
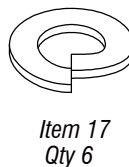
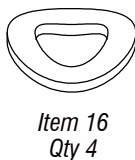
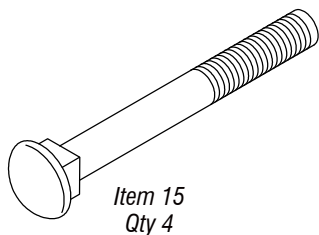

All accessories are drawn to scale.

Assembly & Adjustments



Beny Sports Co. UK Ltd.

Unit 8 Riparian Way,
The Crossings Business Park,
Cross Hills,
West Yorkshire.
BD20 7BW

Carefully unpack each component, checking against the parts list that you have all the necessary parts to complete the assembly of your product.

Please note that some of the parts may be pre-fitted to major components, so please check carefully before contacting our CUSTOMER SUPPORT team.

In any event, please do not return the product to your retailer before contacting us first.

Tel:- 0800 3 101 202 or
+44 (0) 1535 637711

Email:- support@benysports.co.uk

CUSTOMER SUPPORT is open from 9.00am to 5.00pm from Monday to Friday

1

Attach the Front Stabiliser (3) to the Main Frame (1) using 2 x M8 x 75mm Carriage Bolts (15), 2 x M8 Curved Washers (16), 2 x M8 Spring Washers (17) and 2 x M8 Dome Nuts (18).



Note

Do NOT FULLY TIGHTEN any Bolts, Nuts or Fittings at this stage unless specifically instructed to do so.

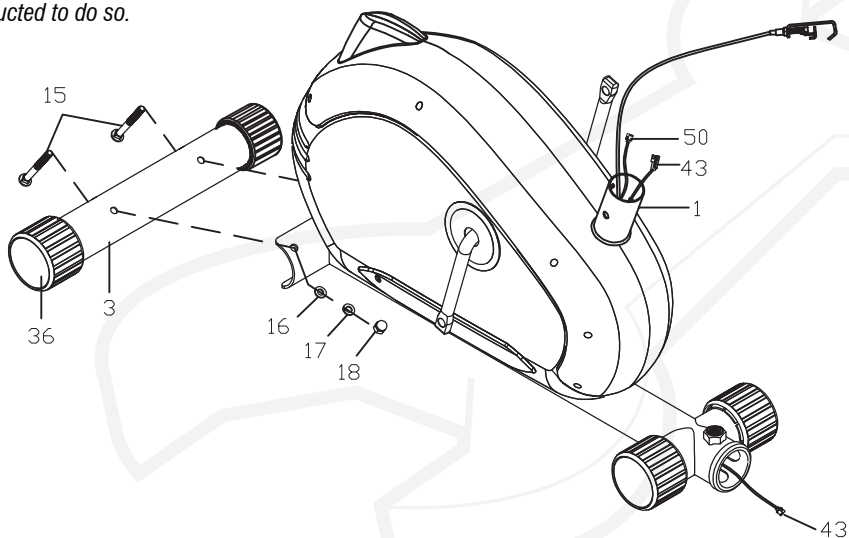

Assembly



- a). Feed the Tension Control Wire (49) up through the Handlebar Upright (7) and out through the hole at the front, as shown below. Place the end of the Tension Control Knob (54) into the spring hook of the Tension Control Cable (49).
- b). Pull the Tension Control Cable upwards against the spring pressure and push it into the gap on the metal bracket of the Lower Tension Cable as shown.
- c). Complete the fitting as shown and if necessary, close the open section of the metal bracket slightly with a pair of pliers as this will help to retain the cables.
- d). Connect the Upper Hand Pulse Wire (41) to the Middle Hand Pulse Wire (43). Connect the Upper Sensor Wire (40) to the Lower Sensor Wire (50). Carefully lower the Handlebar Upright (7) onto the Main Frame (1), then loosely fit 4 x M8 x 20mm Allen Bolts (55), 4 x M8 Spring Washers (17) and 4 x M8 Curved Washers (16). Make sure the Handlebar Support is aligned correctly and tighten all fittings, taking care not to trap any wires.



Note

Do NOT tighten the Handlebar Upright at this stage. The Tension Control Knob (54) must be set at position "8".

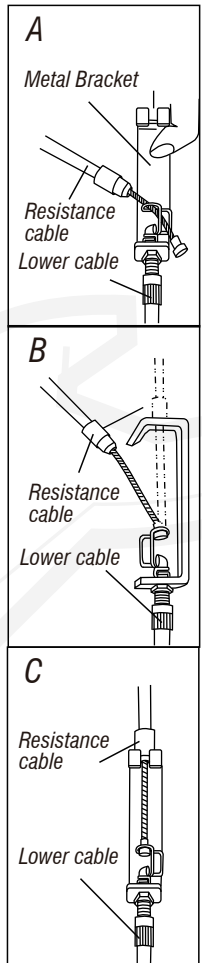
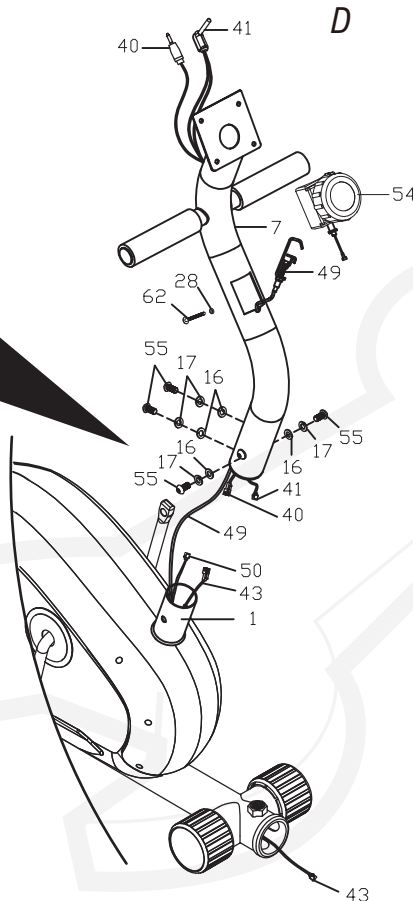
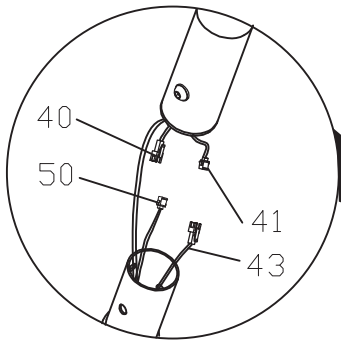

Assembly



- 3** Assemble the Pedals (Left and Right) (20L & R) to the Pedal Crank (9) (See note). Both Pedals **MUST** be tightened securely other wise damage may occur to the Crank. Fit the Pedal Straps (Marked L and R) ensuring a snug, but not tight fit with your normal footwear.



Note

One Pedal is supplied with a **RIGHT HAND THREAD** for the **RIGHT HAND SIDE** and must be fitted by turning **CLOCKWISE**. The other Pedal is supplied with a **LEFT HAND THREAD** for the **LEFT HAND SIDE** and must be fitted by turning **ANTI-CLOCKWISE**.

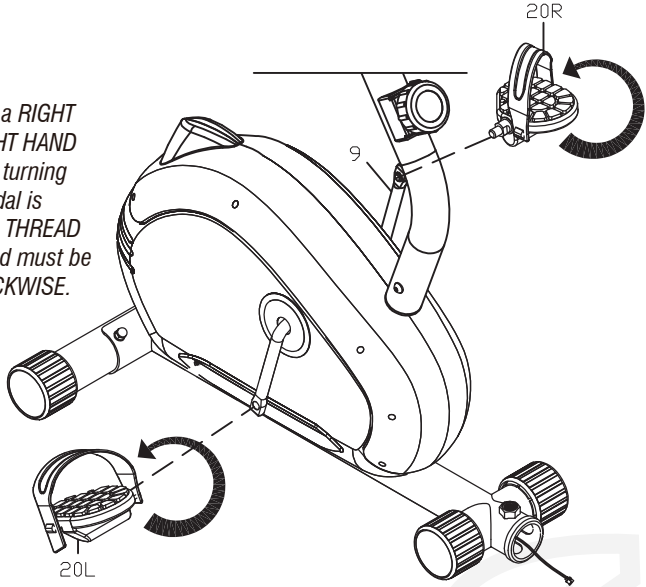

- 4** Attach the Rear Stabiliser (4) to the Saddle Post (2) using 2 x M8 x 75mm Carriage Bolts (15), 2 x M8 Curved Washers (16), 2 x M8 Spring Washers (17) and 2 x M8 Dome Nuts (18).

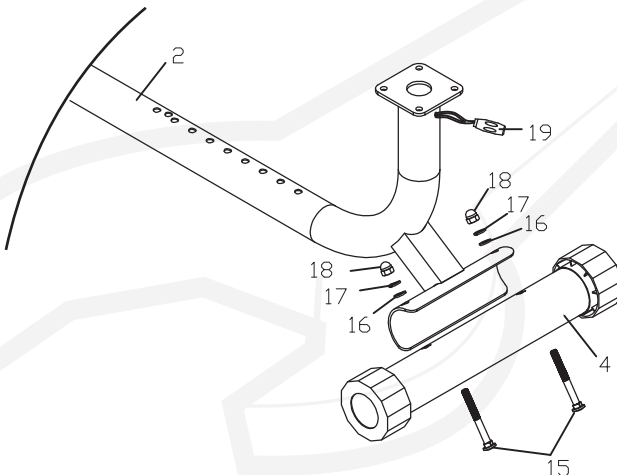

Assembly

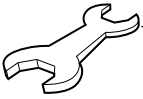

- 5** Connect the Lower Hand Pulse Wire (19) from the Saddle Post (2) to the Middle Hand Pulse Wire (43) from the Main Frame (1).

Slide the Saddle Post (2) into the Main Frame (1) select the desired length to allow for a slight knee bend at the furthest point of the pedaling action and secure in place with Saddle Post Adjustment Knob (42).

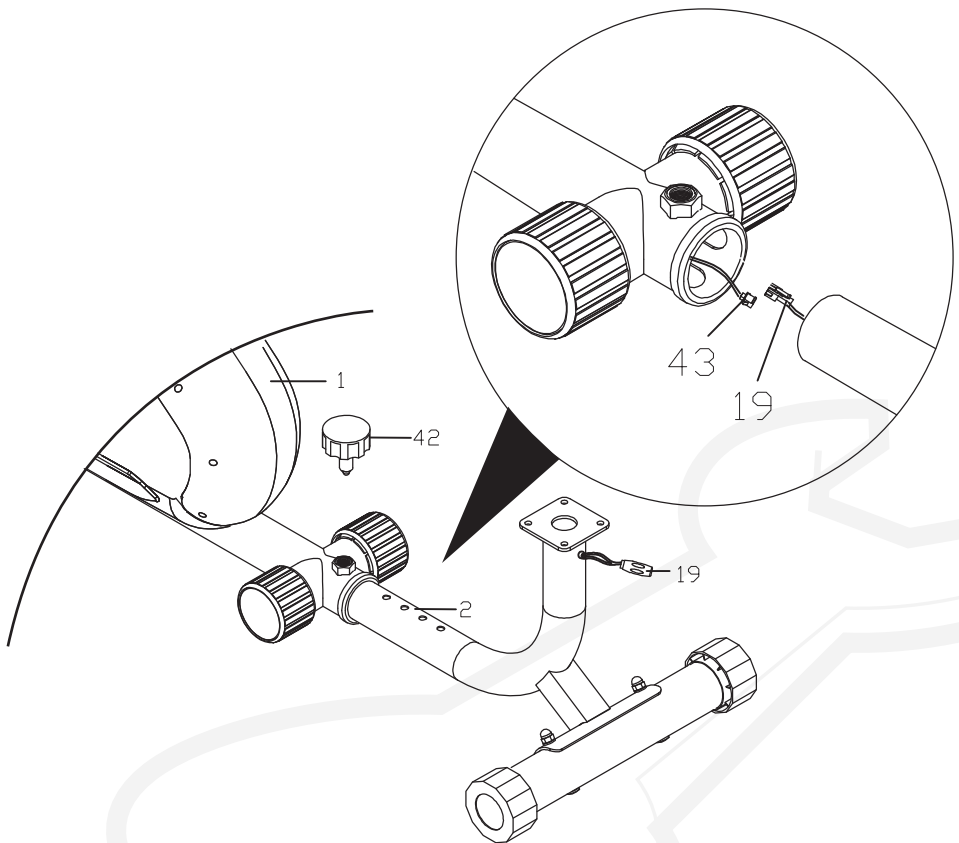

Assembly

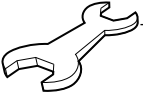

6

Remove 8 x M6 x 20mm Screws (30) and 8 x M6 Flat Washers (26) from the Backrest (24) and the Saddle (23). Install the Saddle (23), Backrest (24) and Saddle Stem (5) using 8 x M6 x 20mm Screws (30) and 8 x M6 Flat Washers (26) that were removed.

Attach the Saddle Stem (5) to the Saddle Post (2) using 4 x M8 x 20mm Allen Bolts (55) and 4 x M8 Flat Washers (8).

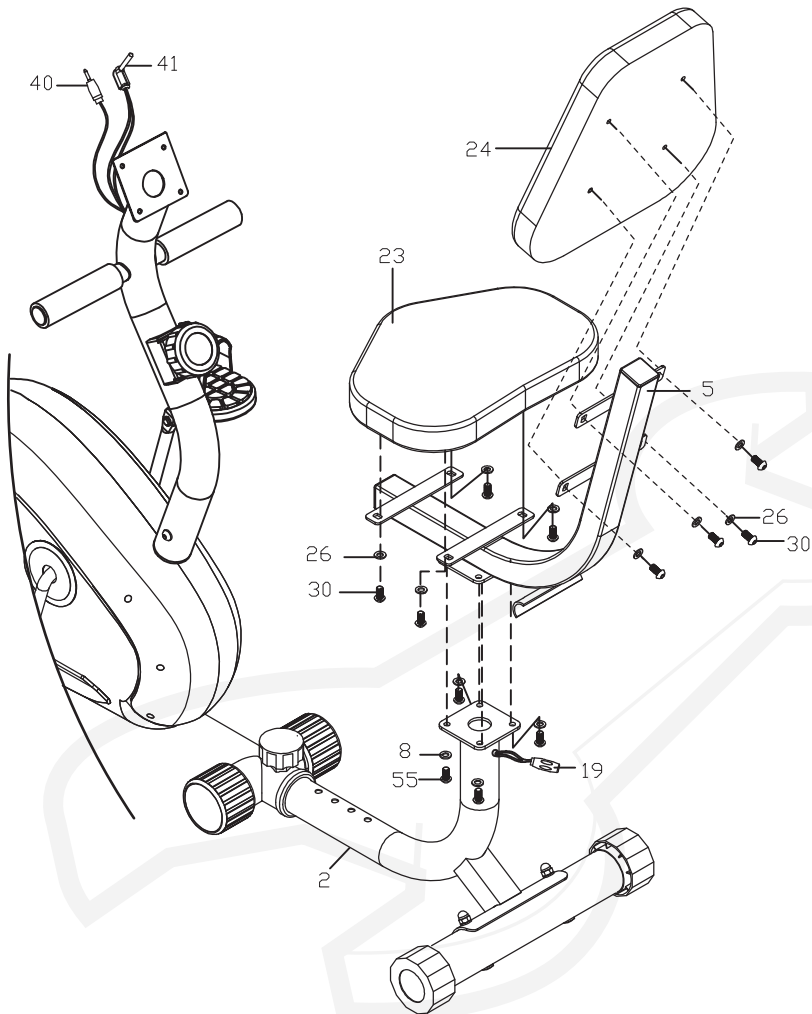

Assembly

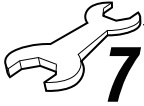

- 7** Attach the Handlebar (6) to the Saddle Stem (5) using 2 x M8 x 45mm Carriage Bolts (22), 2 x M8 Flat Washers (8), 2 x M8 Spring Washers (17) and 2 x M8 Dome Nuts (18). Connect the Hand Pulse Sensor (35) from the Handlebar(6) with the Lower Hand Pulse Wire (19) from the Saddle Post (2). Feed the excess wire back into the hole of the Saddle Post (2).

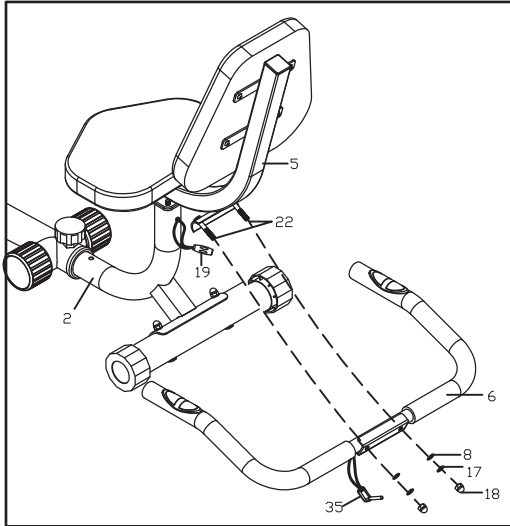

- 8** Remove 4 x M5 x 12mm Screws (59) from the back of the Exercise Monitor (58). Connect the Upper Sensor Wire (40) and the Upper Hand Pulse Wire (41) to the Exercise Monitor (58). Matching like for like and feeding any excess wire back into the Handlebar Upright (7). Carefully slide the Exercise Monitor (58) onto the Exercise Monitor Bracket and secure using 4 x M5 x 12mm Screws (59) that were removed.



Note

FULLY TIGHTEN all Bolts, Nuts and Fittings now, ensuring that your product is located on a clear flat surface before doing so. Your product will now be ready to use.

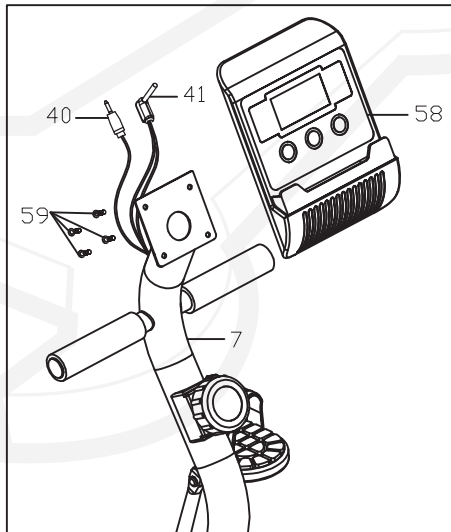

Assembly

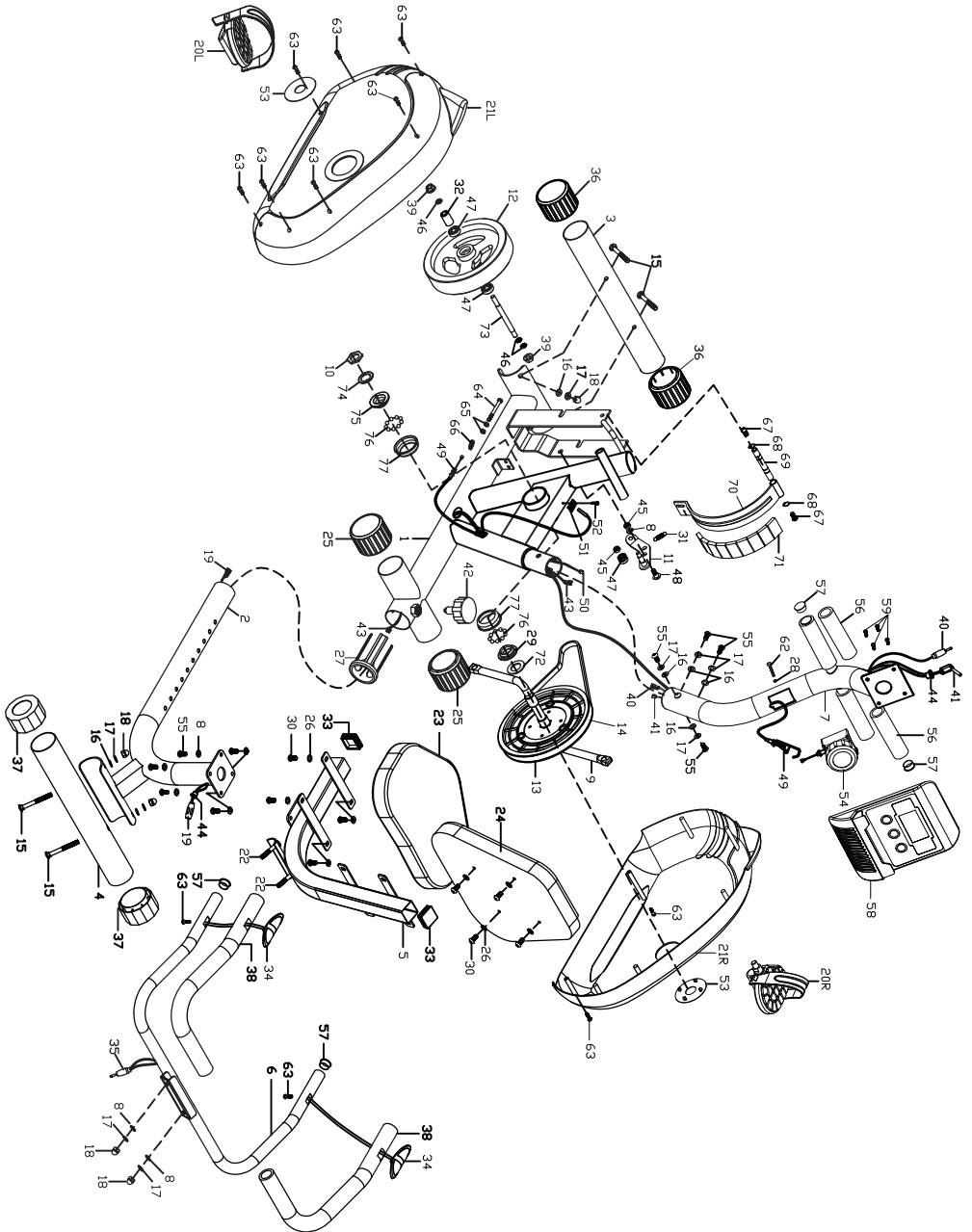

Assembly



MASTER PARTS & ACCESSORY LIST

PART No. DESCRIPTION QTY

1	Main Frame	1
2	Saddle Post	1
3	Front Stabiliser	1
4	Rear Stabiliser	1
5	Saddle Stem	1
6	Handlebar	1
7	Handlebar Upright	1
8	M8 Flat Washer	6
9	Crank	1
10	Hex Nut	1
11	Press Wheel Bracket	1
12	Flywheel	1
13	Drive Wheel	1
14	Belt	1
15	M8 x 75mm Carriage Bolt	4
16	M8 Curved Washer	4
17	M8 Spring Washer	8
18	M8 Dome Nut	6
19	Lower Hand Pulse Wire	1
20	Pedal (L+R)	2
21	Chain Cover (L+R)	2
22	M8 x 45mm Carriage Bolt	2
23	Saddle	1
24	Backrest	1
25	Main Frame End Cap	2
26	M6 Flat Washer	8
27	Saddle Post Insert	1
28	M6 Curved Washer	1
29	Nut 2	2
30	M6 x 20mm Screw	8
31	M20 Spring Washer	1
32	Spacer	1
33	Saddle Stem Cap	2
34	Hand Pulse	2
35	Hand Pulse Sensor	2
36	Front Stabiliser End Cap	2
37	Rear Stabiliser End Cap	2
38	Rear Handlebar Foam Grip	2
39	Flange Nut	2
40	Upper Sensor Wire	1
41	Upper Hand Pulse Wire	2
42	Saddle Post Adjustment Knob	1
43	Middle Hand Pulse Wire	1
44	Grommet	1
45	M8 Nylon Nut	2
46	M10 Hex Nut	2

47	Bearing	2
48	M8 x 20mm Screw	1
49	Lower Tension Wire	1
50	Lower Sensor Wire	1
51	Sensor Wire	1
52	M3 x 12mm Screw	1
53	Crank Cover	2
54	Tension Control Knob	1
55	M8 x 20mm Allen Bolt	8
56	Front Handlebar Foam Grip	2
57	Front Handlebar Cap	4
58	Exercise Monitor	1
59	M5 x 12mm Screw	4
60	Screwdriver	1
61	Spanner	1
62	M5 x 40mm Screw	1
63	M 4 x 20mm Self Tapping Screw	11
64	M6 x 60mm Hex Screw	1
65	M6 Nylon Nut	2
66	M8 x 55mm Spring Washer	1
67	M8 x 15mm Allen Bolt	2
68	Wheel Axle Spring	2
69	Shaft	1
70	Magnet Bracket	1
71	Magnet	9
72	Bearing	2
73	Flywheel Shaft	1
74	Locking Flat Washer	1
75	Nut 1	1
76	Ball Bearing	2
77	Nylon Outer Bearing	2
78	Large Flat Washer	1



Note

Some of the above accessories are pre-fitted to the master component. They may not be supplied separately

EXERCISE MONITOR USER INSTRUCTIONS

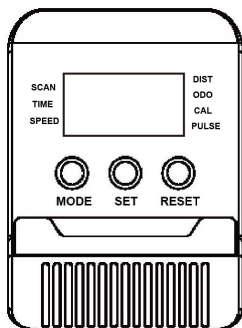

The Exercise Monitor supplied with your product has been specially designed to help you plan and view your exercise performance.

EXERCISE MONITOR FUNCTIONS AND OPERATING SPECIFICATIONS

SCAN	CHANGING FROM FUNCTION TO FUNCTION	SHOWS EACH FUNCTION EVERY 6 SECONDS
TIME	MINUTES AND SECONDS - COUNT UP / DOWN	0.00 - 99.59 Minutes and Seconds
SPEED	REPRESENTATIVE SPEED - KM/H	0.00 - 99.9 Kilometres per Hour
DISTANCE	EXERCISE DISTANCE KM - COUNT UP / DOWN	0.00 - 9999 Kilometres
CALORIE BURN	COMPUTED THEORETICAL CALORIE BURN*	0.1 - 999.9 Kcal THEORETICAL*
PULSE	ACTUAL EXERCISE PULSE RATE**	40 - 240 BEATS per MINUTE**
RPM	CRANKSHAFT REVOLUTIONS PER MINUTE	0 - 1500 RPM
ODOMETER [Total Distance]	ACCUMULATED DISTANCE KM - COUNT UP	0.1 - 999.9 Kilometres

USING YOUR EXERCISE MONITOR

To provide ease of use, there are three touch sensitive / induction reactive buttons on your Exercise Monitor: - **MODE, SET & RESET**.

Press the **MODE** button to manually move through each of the Exercise Monitor's functions. These are - **TIME, SPEED, DISTANCE, CALORIES, RPM, ODOMETER & PULSE**. If you press the **MODE** button until you reach the **SCAN** mode (after **PULSE** mode) then release it, the **SCAN** function will become operative & the display will change approx. **EVERY 6 SECONDS** to show each function in turn.

Pressing the **RESET** button when you are in any mode will enable you to set to zero any previous figures remaining in each individual function except **ODOMETER (TOTAL DISTANCE)** which will continue to accumulate a distance reading unless the Batteries are removed.

START to exercise or press the **MODE** button and the Exercise Monitor will begin to register the various functions. This Exercise Monitor will automatically shut down after approx. 4 Minutes of inactivity.

You are able to set Exercise Targets in the following functions: - **TIME, DISTANCE & CALORIE BURN**. To set targets for these functions, press the **SET** button when the function is active on the LCD screen and this will enable you to programme **TIME, DISTANCE and CALORIE BURN** to count down from your set targets. When the target has been achieved, an alarm will sound for 15 seconds to indicate completion.

Press the **MODE** button until you reach the **PULSE** function. This can be done either while exercising or at rest. **MOISTEN** your **HANDS** slightly before using the Pulse Function to ensure good contact is made on the Sensor Pads. Failure to do this may result in a bad connection and erratic Pulse readings. A representative reading, which should not be used for medical or therapeutic reasons, will show after approximately 7 seconds. The readings will stabilise after approximately 10 seconds.

NOTE: - Please refer to the guide in your Assembly and Training Manual for information and guidance on Exercise Pulse Limits.



Exercise Monitor Instruction

BATTERIES

POWER SOURCE	2 x AA (1.5v) POWER CELLS
STORAGE TEMPERATURE	-10°C - +60°C
NORMAL OPERATING TEMPERATURE	0°C - +40°C

If the display becomes weak or faint, please replace with the correct **BATTERIES** as above.

To fit the necessary **BATTERIES** - (NOT SUPPLIED) to your Exercise Monitor, remove the **BATTERY COVER** at the **REAR** of the monitor. Carefully fit the batteries by fitting between the exposed contacts in the battery compartment.

Ensure that batteries are fitted with the '+' / '-' ends matching the outline on the sticker or in the battery compartment. Failure to fit batteries correctly may result in damage to your Exercise Monitor that is not covered by our guarantee. **PLEASE DISPOSE OF OLD BATTERIES CAREFULLY AND CONSIDERATELY.**



CUSTOMER NOTICE EXERCISE MONITOR CABLE CONNECTION

In most cases where there is an apparent failure of your Exercise Monitor to work, it is due to incorrect fitment of the Exercise Monitor cable connections. So, please ensure that there is **NO GAP** between the connectors on the Exercise Monitor cables when finally assembled.

For **Jack Plug** fittings, push together the Male & Female ends to make initial contact. Push again to make final connection. When fitted correctly, the Jack Plug faces will touch each other.

For **2-Pin** fittings, ensure that you carefully line up the contacts in both connectors and then push firmly together ensuring that the clips lock together.

Before contacting our Customer Support Team (see contact details below), please re-check all cable connections, disconnecting and re-making where necessary.

Should you encounter any difficulty with the operation of your Exercise Monitor that is not solved by re-connection, please return it to us at the address below for inspection.

**WE REGRET THAT ARE UNABLE TO REPLACE ANY DAMAGED
OR FAULTY UNITS BEFORE INSPECTION BY US.**

We reserve the right to repair or replace the Exercise Monitor at our discretion.

Beny Sports Co. UK Ltd.

Unit 8 Riparian Way, The Crossings Business Park, Cross Hills,
West Yorkshire. BD20 7BW

Tel: FREEPHONE 0800 3 101 202 or +44 (0) 01535 637711

e-mail: - support@benysports.co.uk

CUSTOMER SUPPORT is open from 9.00am to 5.00pm from Monday to Friday

V-fit



Beny Sports Co. UK Ltd.

*Unit 8 Riparian Way,
The Crossings Business Park,
Cross Hills,
West Yorkshire
BD20 7BW*

CUSTOMER SUPPORT

Open from 9.00am to 5.00pm from Monday to Friday



*Tel: **FREEPHONE** (in the UK) 0800 3 101 202
or
+44 (0) 1535 637711 (outside the UK)*



E-mail: support@benysports.co.uk



Website: www.benysports.co.uk

© Copyright BSCL - 2019