

V-FIT-ST

SERIAL No. CH2921-UK

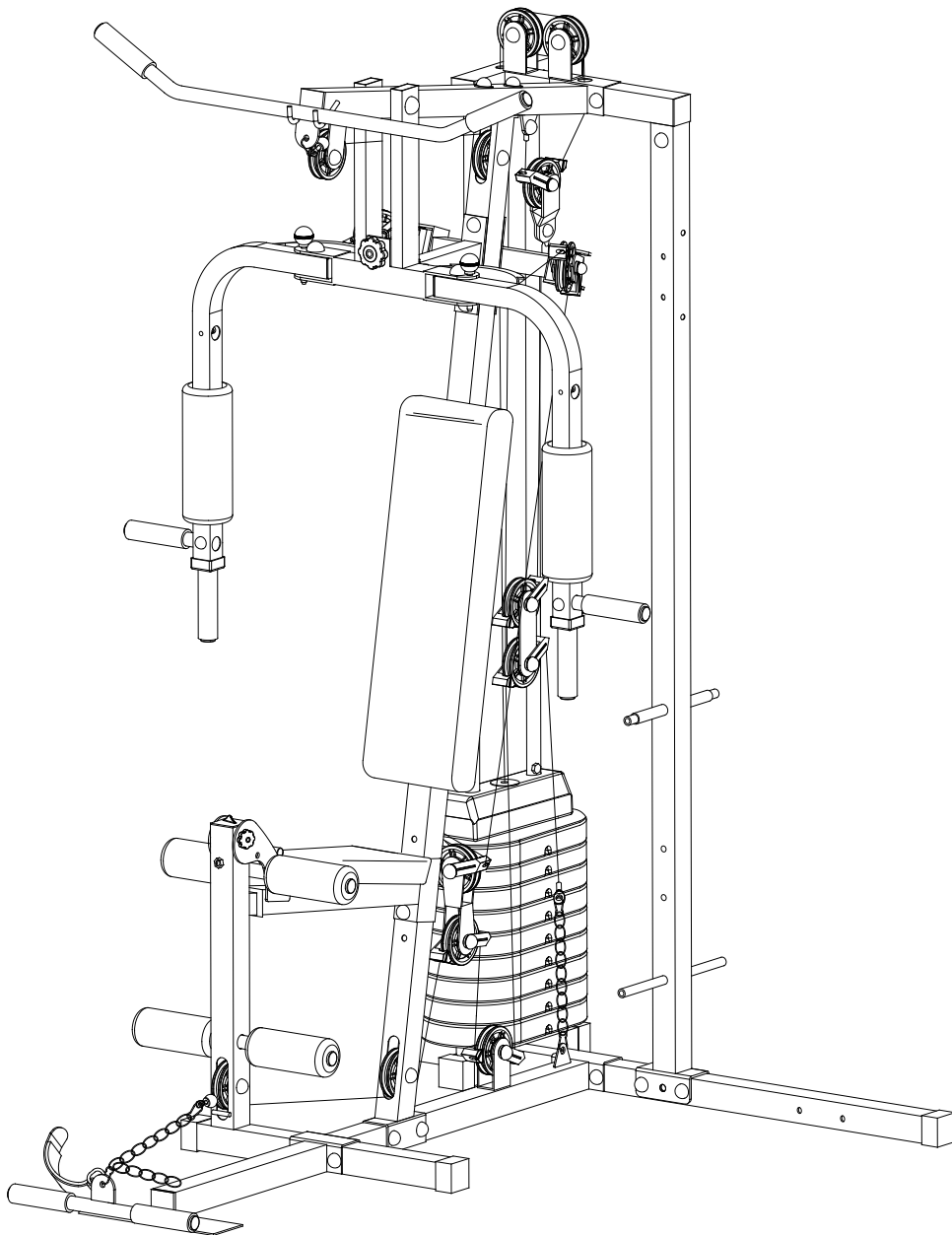

STG/09-2 HERCULEAN COMPACT ADDER HOME GYM

📞 **Call FREEPHONE 0800-3-101-202 for
CUSTOMER SUPPORT (UK ONLY)**

If anything is wrong with your order, or if you have any questions or queries relating to the assembly or operation of this product, please get in touch by e-mail (support@benysports.co.uk) or, by calling our FREEPHONE Number 0800-3-101-202 (for the UK)

or

+44 (0) 1535-637711 (outside the UK),
so we have the opportunity to resolve any problems

Contents

<i>Section</i>	<i>Page</i>
<i>General Information</i>	<i>4</i>
<i>Before you start</i>	<i>5</i>
<i>Safety</i>	<i>6</i>
<i>Exercise Information</i>	<i>7</i>
<i>Assembly</i>	<i>14</i>



Protect the environment by not disposing of this product with household waste.



General Information

Quality

This exercise product has been designed and manufactured to comply with the latest (BS EN 957) British and European Safety Standards.

Questions

Should you encounter any difficulty with the assembly, operation or use of your V-fit exercise product or if you think that you may have parts missing, please **DO NOT** return it to your retailer but contact us first for help and advice, asking for **CUSTOMER SUPPORT**, by any of the following means.

Tel:- 0800 3 101 202 or
+44 (0) 1535 637711
Email:- support@benysports.co.uk
Website: www.benysports.co.uk

CUSTOMER SUPPORT open from 9.00am to 5.00pm
from Monday to Friday

Beny Sports Co. UK Ltd.
Unit 8 Riparian Way,
The Crossings Business Park,
Cross Hills,
West Yorkshire.
BD20 7BW

Queries

If you do have any queries, please ensure that you have the following information ready for our Customer Support Staff:

YOUR NAME
YOUR ADDRESS
YOUR PHONE NUMBER
PRODUCT MAKE OR BRAND
PRODUCT MODEL
PRODUCT SERIAL NUMBER
DATE OF PURCHASE
NAME OF RETAILER
PART NUMBERS REQUIRED

Guarantee

Beny Sports Co. UK Ltd. guarantee's its product range for **DOMESTIC USE ONLY** for a period of **1 YEAR** from the original certified date of purchase. During this period we have the right to: -

- Provide parts for the purchaser to effect repair.
- Repair the product, returned to our warehouse (at the purchaser's cost).
- Replace the product if it is deemed (by us) to be economical to do so.

This guarantee does not cover wear and tear on upholstery or consumables.

This guarantee does not cover abuse, defects caused by storage or use outside those intended.

If you need to advise us of a defect with your product and in order for us to service will requirement for replacement parts or repairs, we will ask for proof of purchase. Failure to do so may result in any claim for replacement parts or repairs being refused.

This guarantee, (both given and implied) applies to the original purchaser only, is not transferable and will be invalidated if used outside of the above criteria.

This guarantee is valid only in the United Kingdom and Eire.

This does not affect your statutory rights as a consumer.

Customer Support

Tel:- 0800 3 101 202 or
+44 (0) 1535 637711
Email:- support@benysports.co.uk
Website: www.benysports.co.uk

CUSTOMER SUPPORT open from 9.00am to 5.00pm
from Monday to Friday

Beny Sports Co. UK Ltd.
Unit 8 Riparian Way,
The Crossings Business Park,
Cross Hills,
West Yorkshire.
BD20 7BW

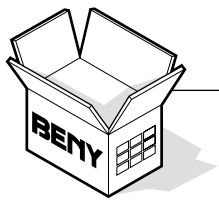

Before You Start

Tools

We suggest below some tools which will enable you to successfully assemble your product.
1 x Soft Headed Hammer & 2 x Adjustable Spanners.

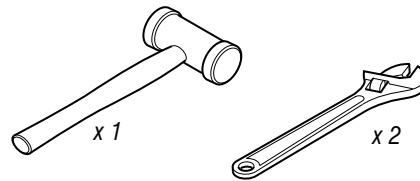

Prepare the Work Area

It is important that you assemble your product in a clean, clear, uncluttered area. This will enable you to move around the product while you are fitting components and will reduce the possibility of injury during assembly.

Work with a Friend

You may find it quicker, safer and easier to assemble this product with the help of a friend as some of the components may be large, heavy or awkward to handle alone.

Open the Carton.

Carefully open the carton that contains your product, taking note of the warnings printed on the carton to ensure that the risk of injury is reduced. Be aware of sharp staples that may be used to fasten the flaps as these may cause injury. Be sure to open the carton the right way up, as this will be the easiest and safest way to remove all the components.

Unpack the Components

Carefully unpack each component, checking against the parts list that you have all the necessary parts to complete the assembly of your product.

Please note that some of the parts may be pre-fitted to major components, so please check carefully before contacting our CUSTOMER SUPPORT team.

In any event, please do not return the product to your retailer before contacting us first.



Safety

Before you undertake any programme of exercise that will increase cardiovascular activity please be sure to consult with your doctor. Frequent strenuous exercise should be approved by your doctor and proper use of your V-fit product is essential. Please read this manual carefully before commencing assembly of your product or starting to exercise.

- * Please keep all children away from exercise products when in use. Do not allow children to climb or play on them when they are not in use.*
- * For your own safety, always ensure that there is at least 1 Metre of free space in all directions around your product while you are exercising.*
- * Regularly check to see that all nuts, bolts and fittings are securely tightened. Periodically checking all moving parts for obvious signs of wear or damage.*
- * Clean only with a damp cloth, do not use solvent cleaners. If you are in any doubt, do not use your V-fit product, but contact CUSTOMER SUPPORT by any of the means listed on the opposite page.*
- * Before use, always ensure that your V-fit product is positioned on a solid, flat surface. If necessary, use a rubber mat underneath to reduce the possibility of slipping in use.*
- * Always wear appropriate clothing and footwear such as training shoes when exercising. Do not wear loose clothing that could become caught or trapped during exercise.*



Warning

If any part of your product becomes damaged, broken or badly worn do not use the equipment until the defective parts have been replaced

Storage and Use

Your V-fit product is intended for use in clean dry conditions. You should avoid storage in excessively cold or damp places as this may lead to corrosion and other related problems that are outside our control.

Weight Limit

*Your V-fit product is suitable for users weighing:
275LBS / 19.6 Stones / 125KG or less.*

Conformity

*This V-fit product conforms to:
(BS EN 957) - PARTS 1 and 2 Class (H) - HOME USE - Class (C).
It is NOT suitable for therapeutic purposes.*



Exercising Information

Beginning

*How you begin to exercise will vary from person to person. If you have not exercised for a long period of time, have been inactive for a while, or are severely overweight you **MUST** start slowly, increasing your exercise time gradually, by perhaps only a few minutes for each session per week.*

Combine a carefully structured nutritious diet with a simple but effective exercise routine and this can help make you feel better, look better and will almost certainly enable you to enjoy life more.

Aerobic Fitness

Aerobic exercise is simply defined as any sustained activity that increases the supply of oxygen to your muscles via the blood pumped by your heart. With regular exercise, your cardiovascular system will become stronger and more efficient. Your recovery rate i.e. the time taken for your heart to reach its normal resting level, will also decrease.

Initially you may only be able to exercise for a few minutes each day. Do not hesitate to breathe through your mouth should you need more oxygen. Use the "talk test". If you cannot carry on a conversation while exercising, you are working too hard! However, aerobic fitness will be gradually built up with regular exercise, over the next six to eight weeks.

Do not be discouraged if it takes longer than this to begin to feel less lethargic, everyone is different and some will achieve their targets quicker than others. Work at your own, comfortable pace and the results will come. The better your aerobic fitness the harder you will have to work to stay in your target zone.



Exercising Information

Warm Up

A successful exercise programme consists of three parts, Warm Up, Aerobic Exercise and Cool Down. Never start a training session without warming up. Never finish one without cooling down correctly. Perform between five and ten minutes of stretching before starting your workout to prevent muscle strains, pulls and cramps.

Aerobic Exercise Session

Those new to exercise should exercise no more than every other day to start with.

As your fitness level increases, increase this to 2 in every 3 days.

When you are comfortable with your routine, exercise for 6 days per week. Always take at least one day off per week.



Note

Incorrect or excessive training may damage your health. Please read the exercise information first.

Exercising in your Target Zone

To ensure that your heart is working in its exercise target zone, you need to be able to take your pulse. If you do not have a pulse monitor (either from the product you are using or a proprietary independent unit) you will need to locate the pulse in your carotid artery. This is situated in the side of the neck and can be felt by using the index and middle fingers. Simply count the number of beats you feel in 10 seconds and then multiply by six to get your pulse rate. This should be taken before you start to exercise for easy reference.

People who have a greater aerobic fitness, have a lower resting pulse level and will also be able to exercise with a higher pulse level.

Target Zone

To determine your target zone, see the chart opposite. If you are new to exercise and by definition unfit, refer to the left column. If you exercise regularly and have good aerobic fitness, refer to the right column.

USERS AGE (Years)	UNCONDITIONED TARGET ZONE - A (Beats per Minute)	CONDITIONED TARGET ZONE - B (Beats per Minute)
20-24	145 - 165	155 - 175
25-29	140 - 160	150 - 170
30-34	135 - 155	145 - 165
35-39	130 - 150	140 - 160
40-44	125 - 145	135 - 155
45-49	120 - 140	130 - 150
50-54	115 - 135	125 - 145
55-59	110 - 130	120 - 140
60 and over	105 - 125	115 - 135



Exercising Information

Cool Down

To decrease fatigue and muscle soreness, you should also cool down by walking at a slow relaxed pace for a minute or so, to allow your heart rate to return to normal.

Warm Up and Cool Down Exercises

Hold each stretch for a minimum of ten seconds and then relax. Repeat each stretch two or three times. Do this before your Aerobic Exercise session and also after you have finished.

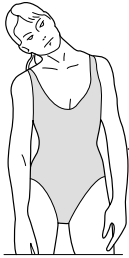

Head Roll

Rotate your head to the right for one count, feeling a slight pull on the left side of your neck. Next, rotate your head back for one count, stretching your chin. Then rotate your head to the left for one count, feeling a slight pull on the right side of your neck. Lastly, drop your head to your chest for one count. Repeat 2 to 3 times.

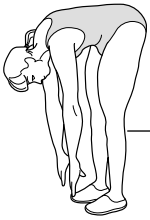

Toe Touch

Slowly bend forward from your waist, letting your back and shoulders relax as you lower your trunk. Gently stretch down as far as is comfortable and hold for 10 seconds.



Shoulder Lift

Rotate and lift your right shoulder up towards your ear for one count. Relax then repeat for the left shoulder. Repeat 3 - 4 times.

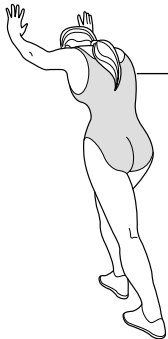

Calf / Achilles Stretch

Turn towards the wall and place both hands on it. Support yourself with one leg while the other is placed behind you with the sole flat on the floor. Bend the front leg and lean towards the wall, keeping the rear leg straight so that the calf and Achilles tendon are stretched hold for 5 seconds. Repeat with the other leg. Repeat 2 - 3 times.



Side Stretch

Open both arms to the side and gently lift them above your head. Reach your right arm as high as you can for one count, gently stretching the muscles of the stomach and lower back. Repeat the action with your left arm. Repeat 3 - 4 times.



Inner Thigh Stretch

Sit on the floor and pull your legs toward your groin, the soles of your feet together. Hold your back straight and lean forward over your feet. Tighten the thigh muscles and hold for 5 seconds. Release and repeat 3 - 4 times.

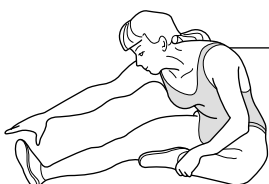

Hamstring Stretch

Sit on the floor with your right leg extended and place your left foot flat against the right inner thigh. Stretch forward toward the right foot and hold for 10 seconds. Relax and then repeat with the left leg extended. Repeat 2 - 3 times.



Exercising Information

Basic Aerobic Training Programme

For your basic Aerobic Exercise routine we suggest that you try the following. Remember, breathe correctly, exercise at your own pace and do not over-train as injury may result.

Week 1 & 2

Warm Up 5 - 10 Minutes
Cool Down 5 Minutes

Exercise 4 minutes at 'A'
Rest 1 minute
Exercise 2 minutes at 'A'
Exercise slowly 1 minute

Week 3 & 4

Warm Up 5 - 10 Minutes
Cool Down 5 Minutes

Exercise 5 minutes at 'A'
Rest 1 minute
Exercise 3 minutes at 'A'
Exercise slowly 2 minutes

Week 5 & 6

Warm Up 5 - 10 Minutes
Cool Down 5 Minutes

Exercise 6 minutes at 'A'
Rest 1 minute
Exercise 4 minutes at 'A'
Exercise slowly 3 minutes

Week 7 & 8

Warm Up 5 - 10 Minutes
Cool Down 5 Minutes

Exercise 5 minutes at 'A'
Exercise 3 minutes at 'B'
Exercise 2 minutes at 'A'
Exercise slowly 1 minute
Exercise 4 minutes at 'A'
Exercise slowly 3 minutes

Week 9 & beyond

Warm Up 5 - 10 Minutes
Cool Down 5 Minutes

Exercise 5 minutes at 'A'
Exercise 3 minutes at 'B'
Exercise 2 minutes at 'A'
Exercise slowly 1 minute
Repeat entire cycle 2 or 3 times

This is only a suggested programme and may not suit every individual's needs.

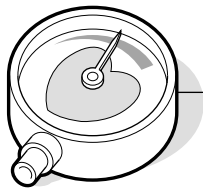

Exercising Information

GETTING STARTED

You will often read about terms referring to exercise that may be confusing. Below are some of the definitions that are regularly used.

Repetition - Commonly referred to as 'REPS'.

This is a complete movement from start to finish.

Set - This is a complete number of consecutive repetitions.

i.e. 1 set of 10 reps.

Speed of Motion - This is the relative speed of movement for each rep.

Fast is considered as 1 rep / second. Medium is 1 rep / 2 seconds. Slow is 1 rep / 4 seconds.

Intensity - How 'hard' the exercise feels.

Low Intensity = easy exercise. High Intensity = hard exercise.

TRAINING PROGRAMMES

You will achieve fast results, gaining a trimmer, fitter body if you follow these general rules.

- * Exercise regularly - do not skip workouts as consistency is the first key to success.
- * Do not be afraid perspire a little. This is a sign that you are working your body hard enough to give fast results. You will find 'hard' exercise enjoyable.
- * Set yourself realistic goals. Do not be over-ambitious. Plan your workouts to concentrate on specific body areas. Start slowly and gradually increase the intensity, reps and sets.

BEGINNERS PROGRAMME

This is a short suggested programme which we suggest you use for no more than 3 weeks, to be ideally performed every other day, but certainly not more than 4 times during the week.

This suggested routine is specifically for beginners or those who have not exercised for a considerable time. The programme is designed to provide general improvement in muscle tone, strength, flexibility and co-ordination.

As a beginner, you should start with no more than 2 sets of 6 exercises for the following reps on each of the Gym's training stations.

10 REPS - BENCH PRESS followed by LAT PULLDOWNS

5 REPS - PEC DEC

10 REPS - SHOULDER SHRUGS

10 REPS - LEG EXTENSIONS followed by LEG CURLS

- * Your rest interval between each set of reps should be 1 minute.
- * You should perform 2 SETS of each exercise.
- * Your exercise pace should be SLOW to MEDIUM.
- * The resistance (weight) settings should be in positions 1 - 3.
- * This exercise programme should take you approximately 20 minutes.
- * Follow this exercise programme with 5 minutes of proper cool down exercises.



Exercising Information

INTERMEDIATE EXERCISE

This is a slightly longer programme which we suggest you use for the next 6 ÷ 8 weeks, to be ideally performed not more than 5 times during the week.

This suggested routine is specifically for intermediate users or those that are familiar with exercise routines. The programme is designed to increase muscle definition, build strength, aid flexibility and co-ordination.

The increase in exercise intensity and speed of repetitions is key to your success at this stage. For intermediate exercise we recommend 3 - 4 sets of 8 exercises for the following reps on each of the Gym's training stations.

15 REPS - BENCH PRESS followed by LAT PULLDOWNS

10 REPS - PEC DEC

15 REPS - SHOULDER SHRUGS

15 REPS - LEG CURLS

15 REPS - LEG EXTENSIONS followed by ARM CURLS

- * Your rest interval between each set of reps should be 1 minute.
- * You should perform 3 - 4 SETS of each exercise.
- * Your exercise pace should be MEDIUM to FAST.
- * The resistance (weight) settings should be in positions 3 - 6.
- * This exercise programme should take you approximately 35 - 40 minutes.
- * Follow this exercise programme with 5 minutes of proper cool down exercises.

ADVANCED TRAINING

This is an open-ended programme, ideally performed not more than 4 times during the week, preferably on alternate days.

This suggested routine is specifically for advanced users or those that are familiar with exercise routines. The programme is designed to increase muscle mass and build strength.

The increase in exercise intensity, resistance levels and speed of repetitions is key to your on going success.

For advanced training we recommend 4 sets of the 9 exercises for the following reps on each of the Gym's training stations. However at this stage you may want to concentrate on specific body parts, so as you are now fully familiar with the workings of your Gym you should be able to structure an exercise programme to suit your own individual needs. Any specific advice should be sought through specialist books.

20 REPS - BENCH PRESS followed by LAT PULLDOWNS

15 REPS - PEC DEC

15 REPS - SHOULDER SHRUGS

15 REPS - LEG CURLS

20 REPS - LEG EXTENSIONS followed by ARM CURLS

15 REPS - FRONT KICKS

10 SLOW REPS - 2 SETS - SIT UPS

- * Your rest interval between each set of reps should be 1 minute.
- * You should perform 4 SETS of each exercise.
- * Your exercise pace should be MEDIUM to FAST.
- * The resistance (weight) settings should be in positions 4 - 8.
- * This exercise programme should take you approximately 40 - 50 minutes.
- * Follow this exercise programme with 5 minutes of proper cool down exercises.

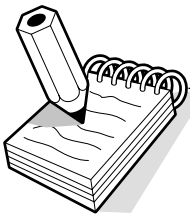

Exercise Notes



Assembly

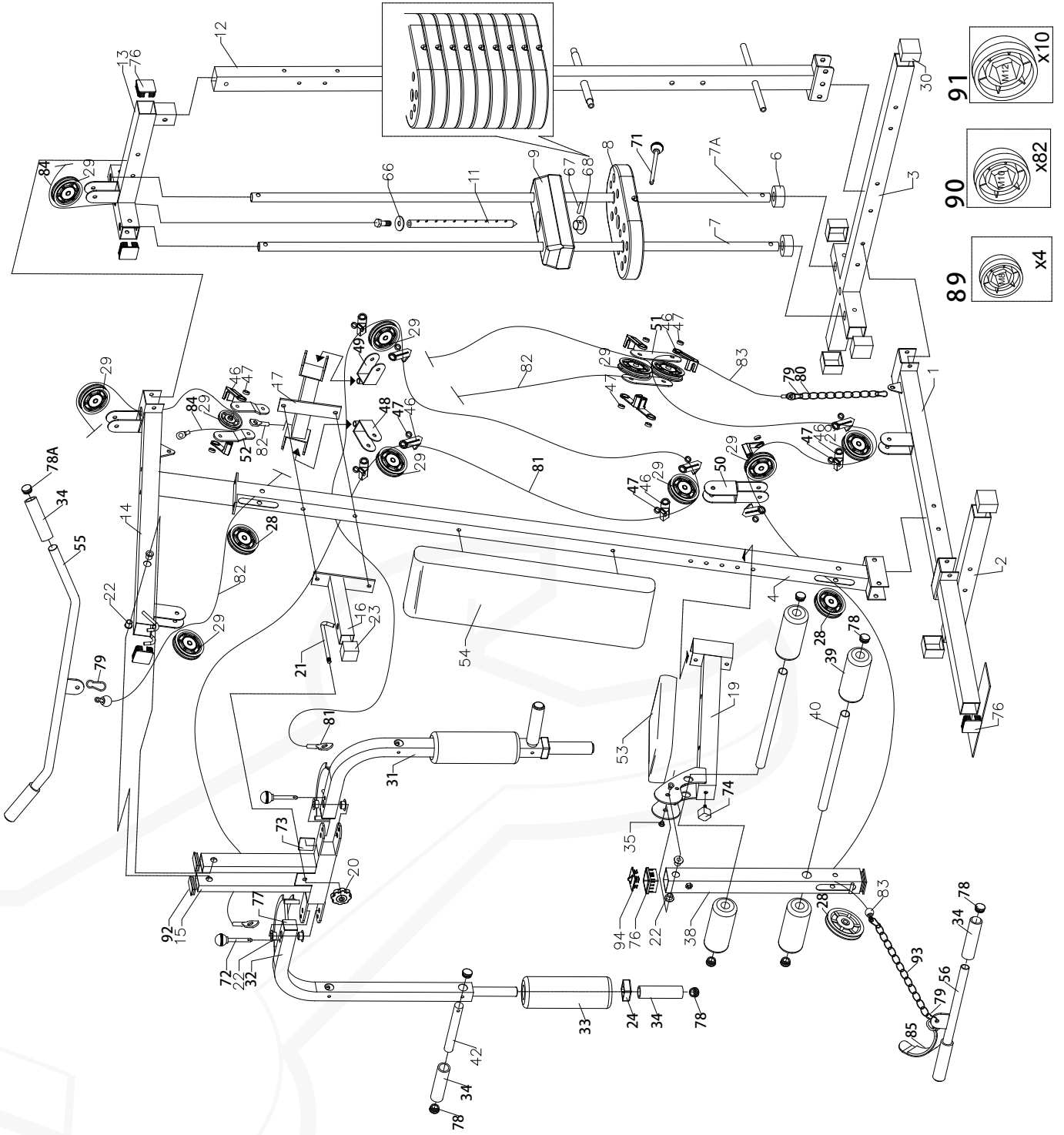
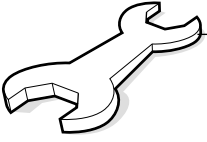

Assembly

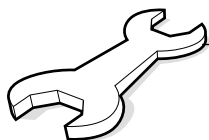

MASTER PARTS & ACCESSORY LIST

PART No.	DESCRIPTION	QTY			QTY
1	MAIN FLOOR FRAME	1	68	CROWN PLATE COLLAR	1
2	FRAME STABILISER (F)	1	71	WEIGHT SELECTOR PIN	1
3	FLOOR FRAME (R)	1	72	PEC ARM LOCK PIN	2
4	FRONT UPRIGHT	1	73	SMALL SQUARE RUBBER PAD	2
6	RUBBER WEIGHT BUMPER	2	74	STOPPER	1
7	WEIGHT GUIDE TUBE	2	75	METAL BUSH	6
8	WEIGHT PLATE	9	76	SQUARE CAP	7
9	CROWN PLATE	1	77	SQUARE INSERT CAP	2
11	WEIGHT SELECTOR TUBE	1	78	ROUND CAP	14
12	REAR UPRIGHT	1	79	CARABINA LOCK CLIP	5
13	REAR FRAME	1	80	LINK CHAIN (SHORT - 9 Link)	1
14	TOP FRAME	1	81	CENTRE (PEC) CABLE	1
15	PRESS FRAME	1	82	TOP (LAT) CABLE	1
16	PRESS FRAME STOP	1	83	LOWER (LEG) CABLE	1
17	PEC ARM MOUNT	1	84	REAR (WEIGHT) CABLE	1
19	SEAT SUPPORT FRAME	1	85	ANKLE STRAP	1
20	PRESS ARM LOCKING KNOB	1	89	M8 SCREW COVER	4
21	FIXED HOOK	1	90	M10 SCREW COVER	82
22	M12 METAL BUSH	8	91	M12 SCREW COVER	10
23	RUBBER SQUARE CAP	1	92	SQUARE END CAP	2
24	SQUARE TRIM	2	94	PLASTIC CAP	1
28	24mm WIDE PULLEY	3	93	LINK CHAIN (LONG - 12 Link)	1
29	28mm WIDE PULLEY	11	100	M10 x 65mm HEX BOLT	12
30	RUBBER CAP	7	101	M10 x 75mm HEX BOLT	14
31	PEC ARM (R)	1	102	M10 FLAT WASHER	76
32	PEC ARM (L)	1	103	M10 NYLON LOCKNUT	39
33	PEC ARM FOAM ROLLER	2	104	M10 x 70mm HEX BOLT	2
34	PRESS / BAR FOAM GRIP	8	105	M10 x 2mm x 38T FLAT WASHER	2
35	M8 METAL BUSH	2	106	M10 x 60mm HEX BOLT	8
36	HOLLOW CAP	1	107	M10 x 50mm HEX BOLT	3
38	LEG UNIT	1	108	M8 x 60mm HEX BOLT	1
39	LEG UNIT FOAM ROLLER	4	110	M12 x 125mm HEX BOLT	1
40	LEG UNIT ROLLER BAR	2	111	M12 FLAT WASHER	10
42	PRESS HANDLE	2	112	M12 NYLON LOCKNUT	5
43	M8 LOCKING KNOB (FEMALE)	2	113	M12 x 70mm HEX BOLT	2
44	LOCKING BOLT	1	114	M12 x 80mm HEX BOLT	2
46	PULLEY LEAD BRACKET	16	115	M8 FLAT WASHER	4
47	M10 SLEEVE	16	117	M8 NYLON LOCKNUT	3
48	PEC SWIVEL BKT (R)	1	118	M8 x 45mm HEX BOLT	2
49	PEC SWIVEL BKT (L)	1	121	M10 x 25mm HEX BOLT	4
50	DOUBLE PULLEY BKT	1			
51	PULLEY MOUNT BKT	2			
52	JOCKEY PULLEY BKT	2			
53	GYM SEAT	1			
54	GYM BACKREST	1			
55	LAT PULLDOWN BAR	1			
56	TRICEPS BAR	1			
66	CROWN PLATE WASHER	1			
67	CROWN PLATE PIN	1			

Assembly

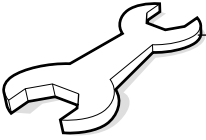

Beny Sports Co. UK Ltd.
Unit 8 Riparian Way,
The Crossings Business Park,
Cross Hills,
West Yorkshire.
BD20 7BW

Carefully unpack each component, checking against the parts list that you have all the necessary parts to complete the assembly of your product.

Please note that some of the parts may be pre-fitted to major components, so please check carefully before contacting our CUSTOMER SUPPORT team.

In any event, please do not return the product to your retailer before contacting us first.

Tel:- 0800 3 101 202 or
+44 (0) 1535 637711

Email:- support@benysports.co.uk

CUSTOMER SUPPORT open from 9.00am to 5.00pm
from Monday to Friday



Note

Do NOT FULLY TIGHTEN any Bolts, Nuts or Fittings at this stage unless specifically instructed to do so.

INSTRUCTIONS:- STAGE A

TOOLS REQUIRED

1 x Soft Headed Hammer - 1 x Adjustable Spanner - 1 x 13mm (1/2") Spanner - 1 x 14mm (9/16") Spanner

ASSEMBLY OF THIS GYM WILL BE EASIER WITH 2 PEOPLE

- 1 Securely attach the Front Frame Stabiliser (2) to the front end of the Main Floor Frame (1) using 2 x M10 x 75mm Hex Bolts (101), 4 x M10 Flat Washers (102) and 2 x M10 Nylon Locknuts (103).
- 2 Lay the Rear Upright (12) on top of the Rear Frame Stabiliser (3) making sure the longest part of the bottom bracket is facing the weight guide tubes and secure in place using 2 x M10 x 75mm Hex Bolts (101), 4 x M10 Flat Washers (102) and 2 x M10 Nylon Locknuts (103).
- 3 Attach the Rear Frame Stabiliser (3) to the Main Floor Frame (1) by lifting the Main Floor Frame (1) over the Rear Frame and secure in place using 2 x M10 x 75mm Hex Bolts (101), 4 x M10 Flat Washers (102) and 2 x M10 Nylon Locknuts (103).
- 4 Cap both Frame Stabilisers (2 and 3) and the central Main Floor Frame Support (1) with 6 x Rubber Caps (30) and 1 x Square Cap (76) securing in place using a small amount of household adhesive if desired.
- 5 Loosely attach the Front Upright (4) to the Main Frame (1) from the side with 2 x M10 x 75mm Hex Bolts (101), 4 x M10 Flat Washers (102) and 2 x M10 Nylon Locknuts (103).
- 6 Slide the 2 x Rubber Weight Bumpers (6) onto the bottom of each Weight Guide Tube (7). Pass both Weight Guide Tubes (7) into the holes in the central Main Floor Frame Support (1), and secure in place with 2 x M10 x 65mm Hex Bolts (100), 4 x M10 Flat Washers (102) and 2 x M10 Nylon Locknuts (103), then lay all the large Weight Plates (8) making sure they are the correct way round with the center edge slot at the bottom of each weight. Ensure the hole 3/4 of the way down the Guide Tube (7) is positioned at the bottom when installing the Guide Tubes(7) into the Main Floor Frame Support (1).
- 7 Slide the 10 hole Weight Selector Tube (11) into the central hole in the weight stack. Place the Crown Weight Collar (68) over the top of the Weight Selector Tube (11). Line up the top hole of the Weight Selector Tube (11) with the hole in the Crown Weight Collar (68) and slide in the Crown Weight Pin (67) so that it is loosely attached. Finally, lay the Crown Weight (9) over the top of the Weight Selector Tube (11) so the Crown Weight Collar (68) fits into the recess on the underside of the Crown Weight (9) and lay the Crown Weight Washer (66) on top of the Crown Weight (9).

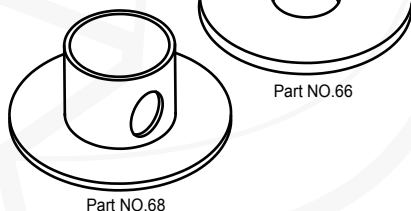
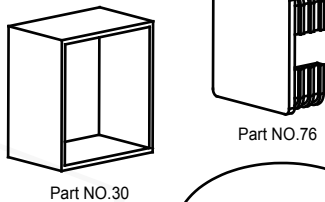
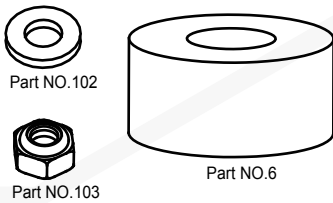
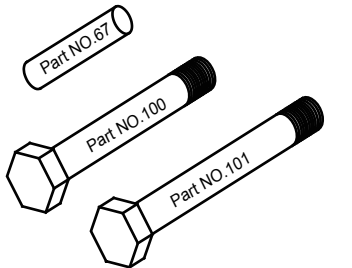

ASSEMBLY ACCESSORIES

PART No.	DESCRIPTION	QTY
06	Rubber Weight Bumper	2
30	Rubber Cap	7
66	Crown Plate Washer	1
67	Crown Plate Pin	1
68	Crown Plate Collar	1
76	Square Cap	1
100	M10 x 65mm Hex Bolt	2
101	M10 x 75mm Hex Bolt	8
102	M10 Flat Washer	20
103	M10 Nylon Locknut	10

Assembly

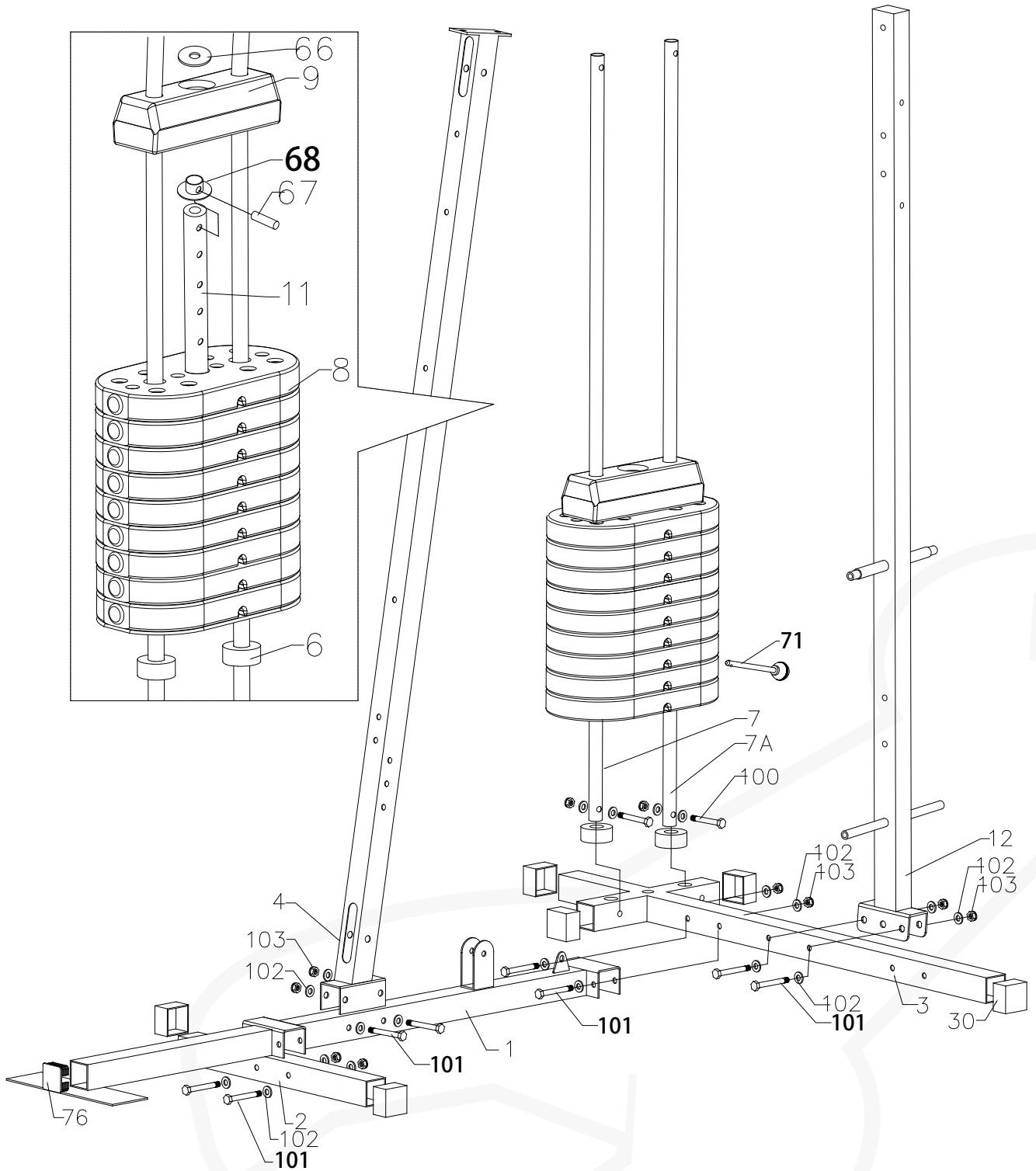
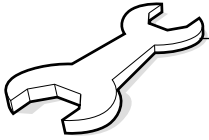

Assembly

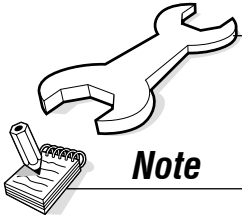

Note

There are 3 positions for height of seat.

INSTRUCTIONS:- STAGE B

- 8** Fit the Seat Support Frame (19) to the Front Upright (4) with 2 x M10 x 75mm Hex Bolts (101), 4 x M10 Flat Washers (102) and 2 x M10 Nylon Locknuts (103).
- 9** Cap the front end of the Seat Support Frame (19) by screwing the Leg Unit Stopper (74) into the Frame as shown. Align the Gym Backrest (54) with the Front Upright (4) and attach to using 2 x M10 x 65mm Hex Bolts (100) and 2 x M10 Flat Washers (102).
- 10** Fit the Gym Seat (53) to the Seat Support Frame (19) using 2 x M10 x 65mm Hex Bolts (100) and 2 x M10 Flat Washers (102).
- 11** Fit 2 x M12 Metal Bushes (22) into the Leg Unit (38) and then fit this into the bracket in the Seat Support Frame (19) using 2 x M8 Locking Knobs (Female) (43), 1 x M8 Locking Bolt (44) and 2 x M8 Metal Bushes (35).
- 12** Fit a Leg Unit Roller Bar (40) to the top hole in the Seat Support Frame (19) and slide on 2 x Leg Unit Foam Rollers (39). Repeat the operation for the lower hole in the Leg Unit (38).
- 13** Cap the ends of the Leg Unit Stabiliser (38) with 2 x Square Caps (76). Insert the Plastic Sleeve (36) into the top of the Leg Unit (38). Now fit the Plastic Top Cap (94) into the Plastic Sleeve (36). The Plastic Top Cap (94) can be removed for the Arm Curl Attachment (Not Supplied).

ASSEMBLY ACCESSORIES

PART No.	DESCRIPTION	QTY
22	M12 Metal Bush	2
35	M8 Metal Bush	2
36	Plastic Sleeve	1
43	M8 Locking Knob (Female)	2
44	M8 Locking Bolt	1
74	Stopper	1
76	Square Cap	2
94	Plastic Top Cap	1
100	M10 x 65mm Hex Bolt	4
101	M10 x 75mm Hex Bolt	2
102	M10 Flat Washer	8
103	M10 Nylon Locknut	2

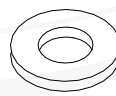
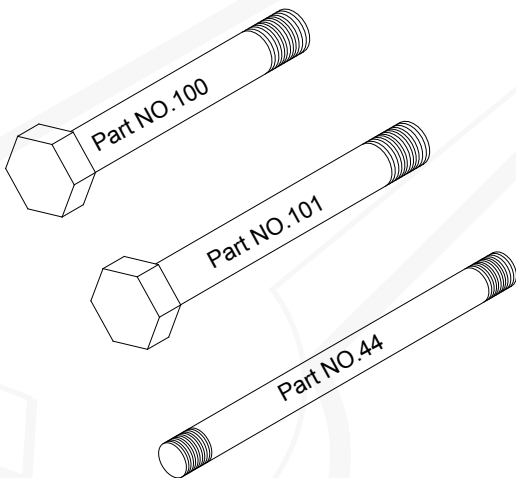

Part NO.102



Part NO.103

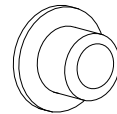

Part NO.22

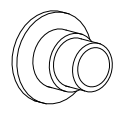

Part NO.35

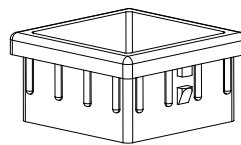

Part NO.36

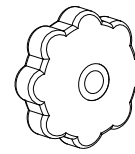

Part NO.43

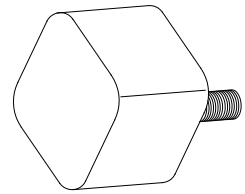

Part NO.74

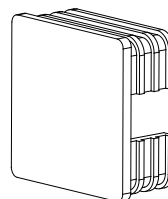

Part NO.76

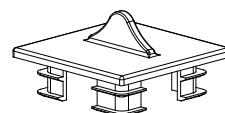

Part NO.94

Assembly

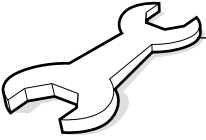

! WARNING !

Do NOT use the Leg Unit with the Preacher Curl Pad fitted as injury could occur to legs, thighs or abdomen.

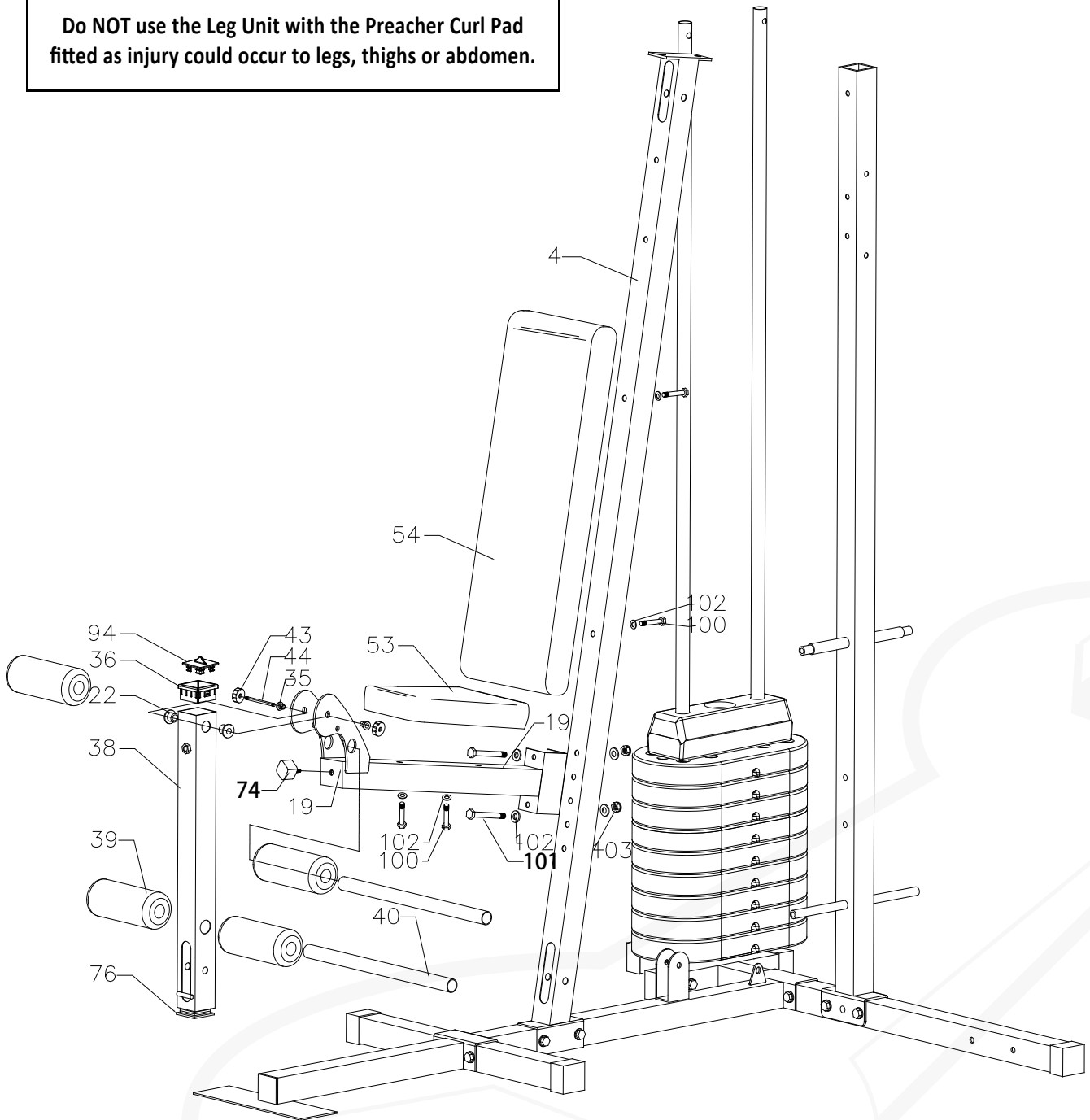

Assembly

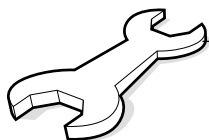

INSTRUCTIONS:- STAGE C

- 14** Attach the Rear Frame (13) to the Rear Upright (12) ensuring that the tops of the Weight Guide Tubes (7) are located in the round holes in the underside of the Rear Frame (13), using 1 x M10 x 65mm Hex Bolts (100), 2 x M10 Flat Washers (102) and 1 x M10 Nylon Locknut (103).
- 15** Secure the Weight Guide Tubes (7) to the Rear Frame (13) using 2 x M10 x 65mm Hex Bolts (100), 4 x M10 Flat Washers (102) and 2 x M10 Nylon Locknuts (103).
- 16** Loosely attach the front of the Top Frame (14) to the Front Upright (4) using 2 x M10 x 70mm Hex Bolts (104), 2 x M10 x 2mm x 38T Flat Washers (105), 2 x M10 Flat Washers (102) and 2 x M10 Nylon Locknuts (103) then put the rear of the Top Frame (14) onto the Rear Frame (13) assembly and align the holes using 2 x M10 x 75mm Hex Bolts (101), 4 x M10 Flat Washers (102) and 2 x M10 Nylon Locknuts (103).
- 17** Cap the exposed open ends of the Top Frame (14) and the Rear Frame (13) with 4 x Square Caps (76), secure in place using a small amount of household adhesive if desired.
- 18** Fit 2 x Metal Bushes (22) to the holes on either side of the Top Frame (14) and then assemble the Press Frame (15) to the Top Frame (14) with 1 x M12 x 125mm Hex Bolt (110), 2 x M12 Flat Washers (111) and 1 x M12 Nylon Locknut (112).
- 19** Fit 2 x Metal Bushes (22) to the large holes in each Pec Arm (31 and 32) and assemble each Pec Arm to the Press Frame (15) using 1 x M12 x 70mm Hex Bolt (113), 2 x M12 Flat Washers (111) and 1 x M12 Nylon Locknut (112). Align the Pec Arms by fitting a Pec Arm Lock Pin (72) to the outer hole in the Press Frame (15) then fully tighten both Hex Bolts.
- 20** Slide 1 x Pec Arm Foam Roller (33) onto each Pec Arm (31 and 32) and then fit 1 x Press Handle (42) to each Pec Arm using 1 x M8 x 45mm Hex Bolt (118), 2 x M8 Flat Washers (115) and 1 x M8 Nylon Locknut (117) for each Press Handle.
- 21** Slide a Press / Bar Foam Grip (34) on to the welded Press Tube of each Pec Arm (31 and 32).
- 22** Cap both exposed Pec Arm inner tube ends with 1 x Square Insert Cap (77) and the lower end with 1 x Square Trim (24) to each Pec Arm (31 and 32), securing in place using a small amount of household adhesive if desired.
- 23** Remove the backing paper and fit 2 x Small Square Rubber Pads (73) to the back face of the Press Frame where the Pec Arms touch the Press Frame.
- 24** Pass the 1 x Fixed Hook (21) through the bottom hole of the Press Frame (15) then secure in place using 1 x Press Arm Locking Knob (20).
- 25** Assemble the Press Frame Stop (16) to the FRONT FACE of the Front Upright (4) and the Pec Arm Mount (17) to the REAR FACE of the Front Upright (4) using 2 x M10 x 75mm Hex Bolts (101), 4 x M10 Flat Washers (102) and 2 x M10 Nylon Locknuts (103). Cap the FRONT open end of the Press Frame Stop (16) with the 1 x Rubber Square Cap (23).



Note (18)

Fully tighten the Hex Bolt to remove any existing freewheel from the Press Frame.



Note

Fitment of the Foam Grips will be easier with a small amount of spray furniture polish inside the foam tube.

ASSEMBLY ACCESSORIES

PART No.	DESCRIPTION	QTY
20	Press Arm Locking Knob	1
21	Fixed Hook	1
22	Metal Bush	6
23	Rubber Square Cap	1
24	Square Trim	2
73	Small Square Rubber Pad	2
76	Square Cap	4
77	Square Cap	2
92	Square End Cap	2
100	M10 x 65mm Hex Bolt	3
101	M10 x 75mm Hex Bolt	4
102	M10 Flat Washer	16
103	M10 Nylon Locknut	9
104	M10 x 70mm Hex Bolt	2
105	M10 x 2mm x 38T Flat Washer	2
110	M12 x 125mm Hex Bolt	1
111	M12 Flat Washer	6
112	M12 Nylon Locknut	3
113	M12 x 70mm Hex Bolt	2
115	M8 Flat Washer	4
117	M8 Nylon Locknut	2
118	M8 x 45mm Hex Bolt	2

Assembly

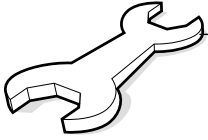

INSTRUCTIONS:- STAGE D

SEE EXPLODED DIAGRAM ON PAGE 25 FOR GUIDANCE ON FITTING THE CABLES AND PULLEYS

26 PULLEY FITMENT

- i). Fit a 28mm wide Pulley (29) to the Front Upper Pulley Bracket on the Top Frame (14) using 1 x M10 x 50mm Hex Bolt (107), 2 x M10 Flat Washers (102) and 1 x M10 Nylon Locknut (103).
- ii). Fit 2 x Metal Bushes (75) to the Upper Pulley cut-out in the Front Upright (4) then secure a 24mm wide Pulley (28) using 1 x M10 x 65mm Hex Bolt (100) and 1 x M10 Nylon Locknut (103).
- iii). Fit 2 x 28mm wide Pulleys (29) to the Rear Upper Pulley Brackets on the Top Frame (14) using 1 x M10 x 50mm Hex Bolt (107), 2 x M10 Flat Washers (102) and 1 x M10 Nylon Locknut (103) for each pulley.
- iv). Fit 2 x Metal Bushes (75) to the Pulley cut-out in the Leg Unit (38) then secure a 24mm wide Pulley (28) using 1 x M10 x 65mm Hex Bolt (100) and 1 x M10 Nylon Locknut (103).
- v). Fit 2 x Metal Bushes (75) to the Lower Pulley cut-out in the Front Upright (4) then secure a 24mm wide Pulley (28) using 1 x M10 x 65mm Hex Bolt (100) and 1 x M10 Nylon Locknut (103).
- vi). Fit a 28mm wide Pulley (29) to the Lower Pulley Bracket on the Main Floor Frame (1) using 1 x M10 x 60mm Hex Bolt (106), 2 x M10 Flat Washers (102), 2 x M10 Sleeves (47), 2 x Pulley Lead Brackets (46) and 1 x M10 Nylon Locknut (103).

27 REAR (WEIGHT) CABLE FITMENT

- i). Screw the threaded end of the Rear (Weight) Cable (84) into the threaded insert in the top of the Weight Selector Tube (11).
- ii). Pull the cable UP and pass it OVER the 2 x Upper Pulleys in the Rear of the Top Frame (14), fitted in Stage 26 (iii) above.
- iii). *** This bracket will be supplied loosely assembled.**
Loosely assemble the 2 parts of the Jockey Pulley Bracket (52) with a 28mm wide Pulley (29), 1 x M10 x 60mm Hex Bolt (106), 4 x M10 Sleeves (47) 2 x M10 Flat Washers (102), 2 x M10 Sleeves (47), 4 x pulley lead brackets (46) and 1 x M10 Nylon Locknut (103).
- iv). Pass the weight cable under the jockey pulley bracket and attach to the Top Frame (14) using 1 x M10 x 25mm Hex Bolt (12), 2 x M10 Flat Washer (102) and 1 x M10 Nylon Locknut (103).

28 TOP (LAT) CABLE FITMENT



Note (28i)

Ensure that the Rubber ball Stopper is fitted to the OUTSIDE of the Pulley bracket.

- i). Thread the Top (Lat) Cable (82) through the Front Upper Pulley Bracket on the Top Frame (14) OVER the Pulley fitted in Stage 26 (i) above.
- ii). Route the cable OVER the Upper Pulley in the Front Upright (4) fitted in Stage 26 (ii) above.
- iii). *** This bracket will be supplied loosely assembled.**
Loosely assemble both of the Pulley Mount Brackets (51) with 2 x 28mm wide Pulleys (29), 2 x M10 x 60mm Hex Bolts (106), 4 x M10 Flat Washers (102), 2 x M10 Sleeves (47), 2 x Pulley Lead Brackets (46) and 2 x M10 Nylon Locknuts (103).
- iv). Pull the cable DOWN to the Pulley Mount Brackets (51), passing it UNDER one of the assembled Pulleys and guide it UP towards the Top Frame (14).
- v). Secure the free end of the cable to the lower part of the assembled Jockey Pulley Bracket (52) using 1 x M10 x 25mm Hex Bolt (121), 2 x M10 Flat Washers (102) and 1 x M10 Nylon Locknut (103).

Assembly

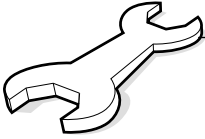

29 LOWER (LEG) CABLE FITMENT



Note

Ensure that the Rubber ball Stopper is fitted to the OUTSIDE of the Leg Unit (38).

- i). Thread the Lower (Leg) Cable (83) through the front of the Leg Unit (38) UNDER the Pulley fitted in Stage 29 (iv) above.
- ii). Pass the cable UNDER the Lower Pulley in the Front Upright (4) fitted in Stage 29 (v) above.
- iii). *** This bracket will be supplied loosely assembled.**
Loosely assemble the Double Pulley Bracket (50) with 2 x 28mm wide Pulleys (29), 2 x M10 x 60mm Hex Bolts (106), 4 x M10 Flat Washers (102), 4 x M10 Sleeves (47), 4 x Pulley Lead Brackets (46) and 2 x M10 Nylon Locknuts (103).
- iv). Route the cable UP to the Double Pulley Bracket (50) and pass it OVER one of the Pulleys.
- v). Pull the cable DOWN and guide it UNDER the Lower Pulley Bracket on the Main Floor Frame (1) fitted in Stage 29 (vi) above.
- vi). Guide the cable UP to the Pulley Mount Brackets (51), passing it OVER the lower Pulley and DOWN towards the welded anchor bracket.
- vii). Secure the free end of the cable to the anchor bracket using 1 x Link Chain (Short - 9 Link) (80) and 2 x Carabina Lock Clips (79).

30 CENTRE (PEC) CABLE FITMENT



Note

The Pec Swivel Brackets (48 and 49) are marked R and L with stickers. These should be fitted to the Pec Arm Mount (17) viewed from the REAR. When fitted, fully tighten the bolts so that all freeplay is removed from the brackets but that it is still possible for them to rotate. These may need to be re-tightened after a few days when the frame coating has worn flat.

- i). Connect one free end of the Centre (Pec) Cable (81) to the REARMOST hole in the curved plate on the back of the Left Pec Arm (32) using 1 x M10 x 25mm Hex Bolt (121), 3 x M10 Flat Washers (102) (one each side of the Pec Cable end and one before fitting the nut) and 1 x M10 Nylon Locknut (103).
- ii). *** These brackets will be supplied loosely assembled.**
Fit the left and right Pec Swivel Brackets (48 and 49) to the Pec Arm Mount (17) using 2 x M12 x 80mm Hex Bolts (114), 4 x M12 Flat Washers (111) and 2 x M12 Nylon Locknuts (112).
Fit 1 x 28mm wide Pulley (29) to each Pec Swivel Bracket (48 and 49) using 1 x M10 x 60mm Hex Bolt (106), 2 x M10 Flat Washers (102), 4 x M10 Sleeves (47), 4 x Pulley Lead Brackets (46) and 1 x M10 Nylon Locknuts (103) for each Pec Swivel Bracket.
- iii). Pass the free end of the Pec Cable OVER the Pulley in the Left Pec Swivel Bracket (49) and DOWN to the Double Pulley Bracket (50) passing it UNDER the top Pulley fitted to the Bracket.
- iv). Route the free end of the Pec Cable UP and guide it OVER the Pulley in the Right Pec Swivel Bracket (48).
- v). Connect the free end of the Pec Cable to the REARMOST hole in the curved plate on the back of the Right Pec Arm (31) using 1 x M10 x 25mm Hex Bolt (121), 3 x M10 Flat Washers (103) (one each side of the Pec Cable end and one before fitting the nut) and 1 x M10 Nylon Locknut (103).



Note

Use the chain to remove slack from the cable system by using fewer links.

Assembly

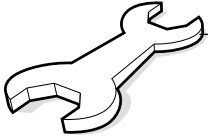

ASSEMBLY ACCESSORIES - STAGE D

PART No.	DESCRIPTION	QTY
28	24mm Wide Pulley	3
29	28mm Wide Pulley	11
46	Pulley Lead Bracket	16
47	M10 Sleeve	16
75	Metal Bush	6
79	Carabina Lock Clip	5
81	Centre (Pec) Cable	1
82	Top (Lat) Cable	1
83	Lower (Leg) Cable	1
84	Rear (Weight) Cable	1
100	M10 x 65mm Hex Bolt	3
102	M10 Flat Washer	32
103	M10 Nylon Locknut	18
106	M10 x 60mm Hex Bolt	8
107	M10 x 50mm Hex Bolt	3
111	M12 Flat Washer	4
112	M12 Nylon Locknut	2
114	M12 x 80mm Hex Bolt	2
121	M10 x 25mm Hex Bolt	4

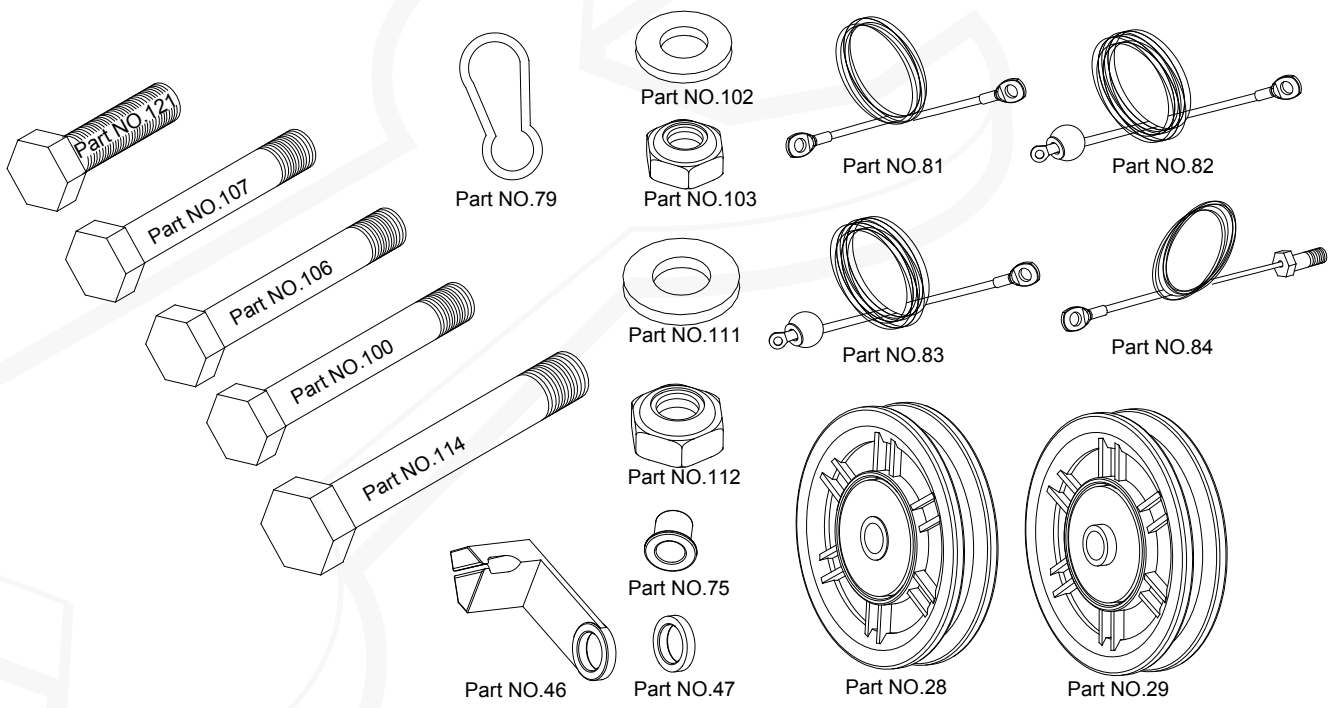

Assembly

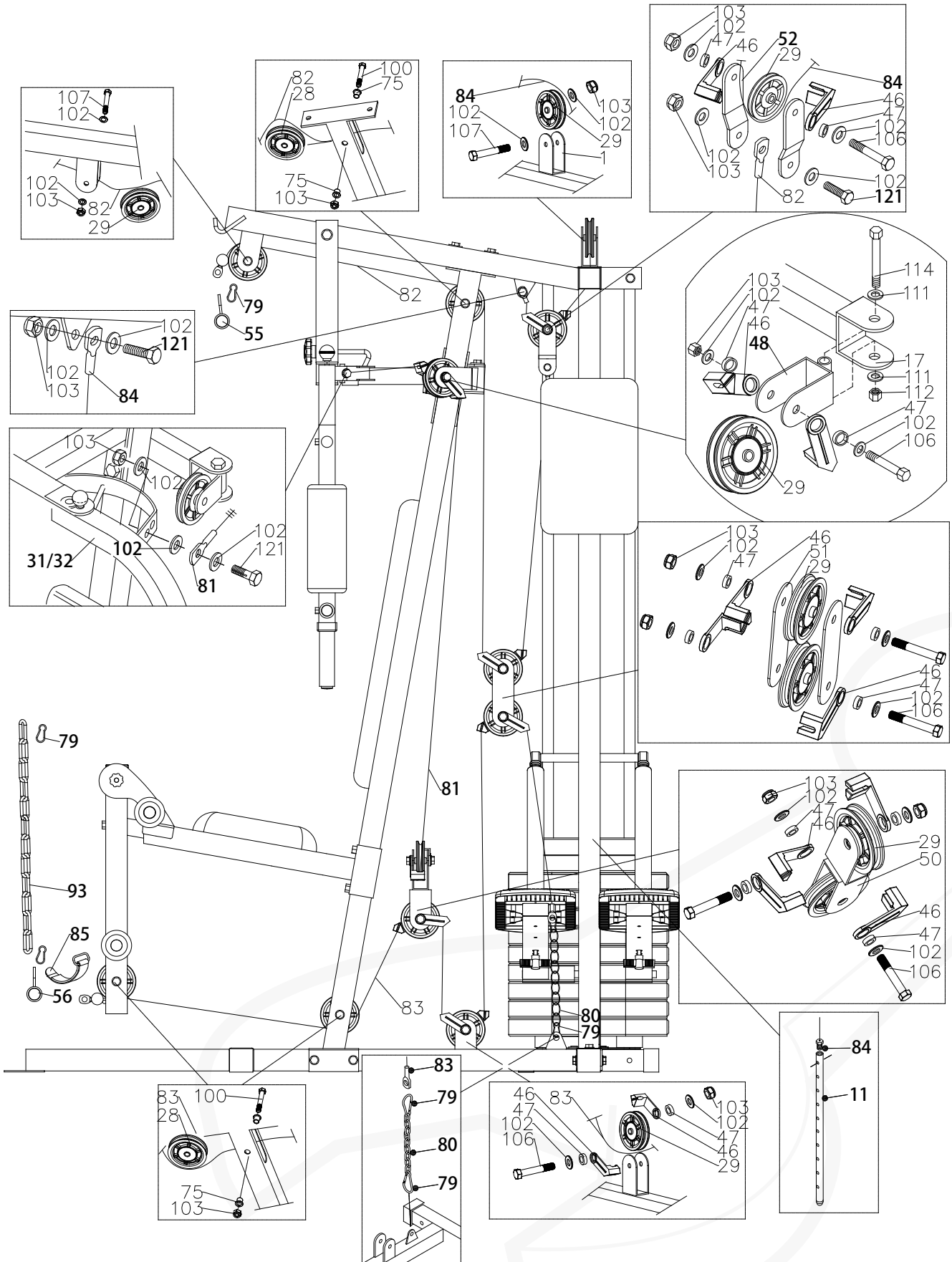
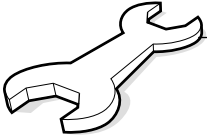

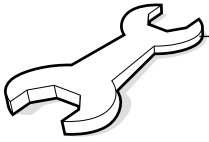

Assembly

INSTRUCTIONS:- STAGE E

- 31** To lock the weight stack for safety when not in use, fit 1 x M8 x 60mm Hex Bolt (108) through the hole of the Weight Guide Tube (7) then secure in place using 1 x M8 Nylon Locknut (117).
- 32** Cap all of the bolts according to there size using the M6 Screw Covers (88), M8 Screw Covers (89), M10 Screw Covers (90), M12 Screw Covers (91).



Note

- 33** M8 In accordance with BS EN 957 Parts 1, 2 & 4, this product is supplied with 1 x M8 x 60mm Bolt and 1 x M8 Nut to facilitate locking the Weight Stack on this Gym to prevent its unauthorised use. These fittings should be inserted and fastened into the punched hole (which is positioned approx 10mm above the Crown Weight Plate when assembled) in one of the Weight Guide Tubes that have previously been assembled in Assembly Stage A and shown opposite.

If extra security is required, a small key operated household padlock, combination lock or other proprietary locking device can also be used in place of this fitting.

!

IT IS THE USERS' RESPONSIBILITY TO ENSURE THAT MOVEMENT OF THE WEIGHT STACK ON THIS GYM IS PREVENTED WHEN NOT IN USE

For additional safety, we suggest that access to the Weight Stack and all moving parts is prevented during use and that this Gym is positioned so that access to the sides and rear of the Gym is not possible during use without the user being aware.

ASSEMBLY ACCESSORIES



Note

FULLY TIGHTEN all Bolts, Nuts and Fittings now, ensuring that your product is located on a clear flat surface before doing so. Your product will now be ready to use.

PART No.	DESCRIPTION	QTY
89	M8 Screw Cover	4
90	M10 Screw Cover	82
91	M12 Screw Cover	10
108	M8 x 60mm Hex Bolt	1
117	M8 Nylon Locknut	1

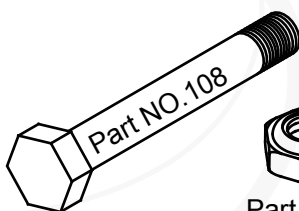

Part NO.117

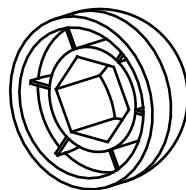

Part NO.89

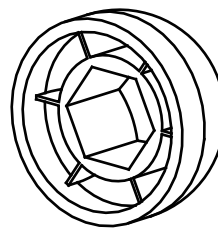

Part NO.90

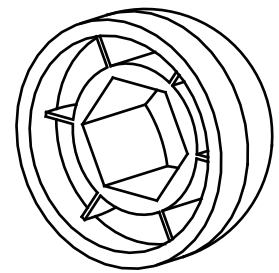

Part NO.91

Assembly

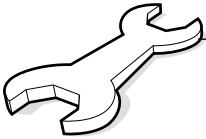

91

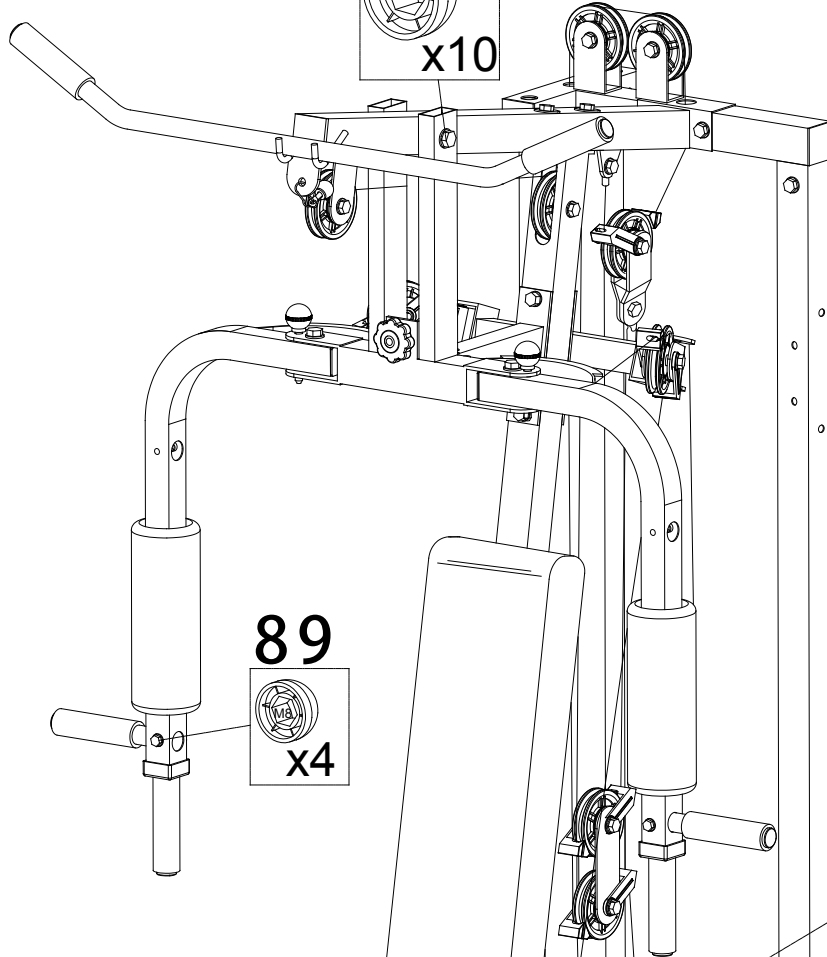
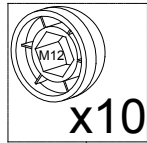

Note

The bars fitted to the Rear Upright (12) are used for the VKR Upgrade Kit which can be purchased separately. Please contact Beny Sports Customer Service Team to purchase your VKR Upgrade.

✉ Beny Sports Co. UK Ltd.

Unit 8 Riparian Way,
The Crossings Business Park,
Cross Hills,
West Yorkshire
BD20 7BW

CUSTOMER SUPPORT

Open from 9.00am to 5.00pm from Monday to Friday

☎ Tel: **FREEPHONE** (in the UK) 0800 3 101 202
or
+44 (0) 1535 637711 (outside the UK)

@ E-mail: support@benysports.co.uk

89

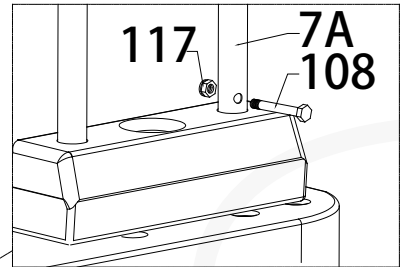
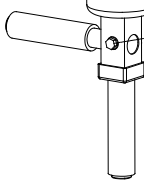

90

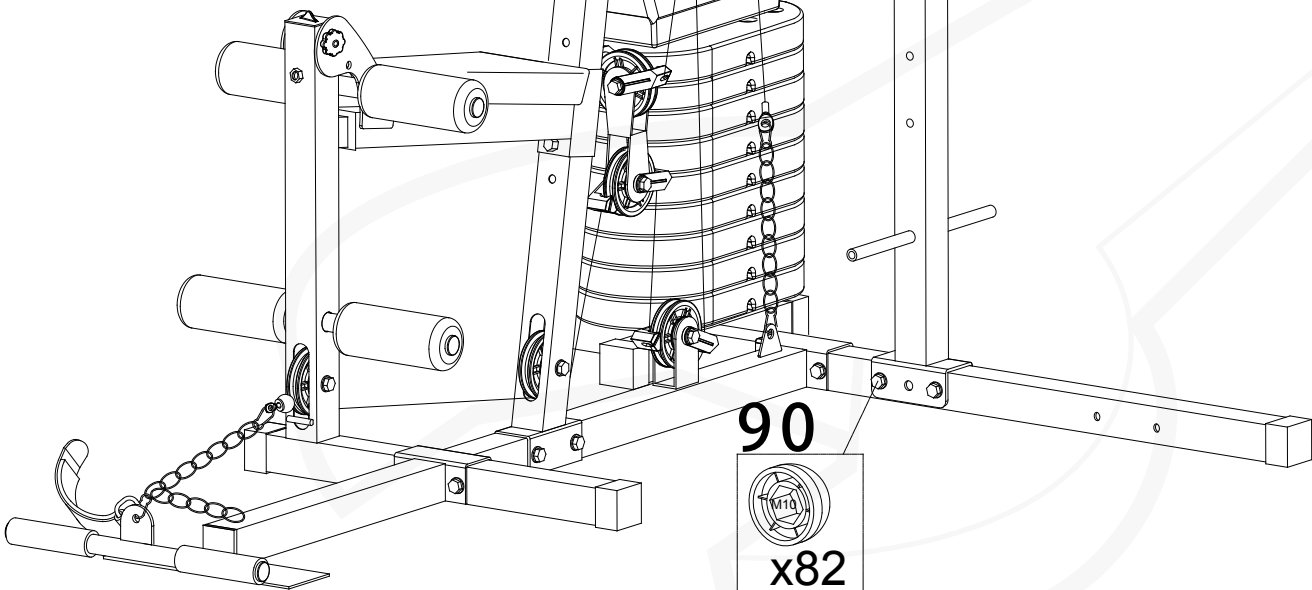

V-FIT-ST

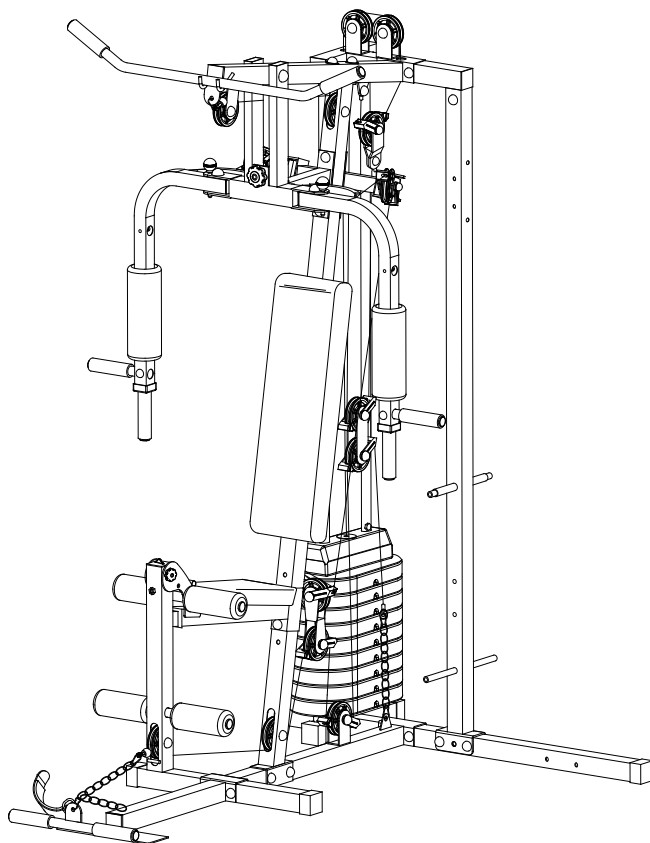

Beny Sports Co. UK Ltd.

*Unit 8 Riparian Way,
The Crossings Business Park,
Cross Hills,
West Yorkshire
BD20 7BW*

CUSTOMER SUPPORT

Open from 9.00am to 5.00pm from Monday to Friday



*Tel: **FREEPHONE** (in the UK) 0800 3 101 202
or
+44 (0) 1535 637711 (outside the UK)*



E-mail: support@benysports.co.uk



Website: www.benysports.co.uk

© Copyright BSCL - 2019