

SERIAL No. AB3098-UK

V-FIT-ST



Herculean LFG2 Home Gym

☎ **Call FREEPHONE 0800-3-101-202 for
CUSTOMER SUPPORT (UK ONLY)**

If anything is wrong with your order, or if you have any questions or queries relating to the assembly or operation of this product, please get in touch by e-mail (support@benysports.co.uk) or, by calling our FREEPHONE Number 0800-3-101-202 (for the UK)

or

+44 (0) 1535-637711 (outside the UK),
so we have the opportunity to resolve any problems

Contents

| <i>Section</i> | <i>Page</i> |
|--|------------------|
| <i>General Information</i> | <i>4</i> |
| <i>Before You Start</i> | <i>5</i> |
| <i>Safety</i> | <i>6</i> |
| <i>Exercise Information</i> | <i>7</i> |
| <i>Assembly</i> | <i>13</i> |



Protect the environment by not disposing of this product with household waste.



General Information

Quality

This exercise product has been designed and manufactured to comply with the latest (BS EN 957) British and European Safety Standards.

Questions

Should you encounter any difficulty with the assembly, operation or use of your V-fit exercise product or if you think that you may have parts missing, please DO NOT return it to your retailer but contact us first for help and advice, asking for CUSTOMER SUPPORT, by any of the following means.

*Tel:- 0800 3 101 202 or
+44 (0) 1535 637711
Email:- support@benysports.co.uk
Website: www.benysports.co.uk*

*CUSTOMER SUPPORT open from 9.00am to 5.00pm
from Monday to Friday*

*Beny Sports Co. UK Ltd.
Unit 8 Riparian Way,
The Crossings Business Park,
Cross Hills,
West Yorkshire.
BD20 7BW*

Queries

If you do have any queries, please ensure that you have the following information ready for our Customer Support Staff:

*YOUR NAME
YOUR ADDRESS
YOUR PHONE NUMBER
PRODUCT MAKE OR BRAND
PRODUCT MODEL
PRODUCT SERIAL NUMBER
DATE OF PURCHASE
NAME OF RETAILER
PART NUMBERS REQUIRED*

Guarantee

Beny Sports Co. UK Ltd. guarantee's its product range for **DOMESTIC USE ONLY** for a period of **1 YEAR** from the original certified date of purchase. During this period we have the right to: -

- a). Provide parts for the purchaser to effect repair.
- b). Repair the product, returned to our warehouse (at the purchaser's cost).
- c). Replace the product if it is deemed (by us) to be economical to do so.

This guarantee does not cover wear and tear on upholstery or consumables.

This guarantee does not cover abuse, defects caused by storage or use outside those intended.

If you need to advise us of a defect with your product and in order for us to service any requirement for replacement parts or repairs, we will ask for proof of purchase. Failure to do so will result in any claim for replacement parts or repairs being refused.

This guarantee, (both given and implied) applies to the original purchaser only, is not transferable and will be invalidated if used outside of the above criteria.

This guarantee is valid only in the United Kingdom and Eire.

This does not affect your statutory rights as a consumer.

Customer Support

*Tel:- 0800 3 101 202 or
+44 (0) 1535 637711
Email:- support@benysports.co.uk
Website: www.benysports.co.uk*

*CUSTOMER SUPPORT open from 9.00am to 5.00pm
from Monday to Friday*

*Beny Sports Co. UK Ltd.
Unit 8 Riparian Way,
The Crossings Business Park,
Cross Hills,
West Yorkshire.
BD20 7BW*

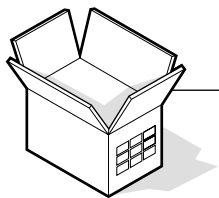

Before You Start

Tools

To enable you to successfully assemble your product. You will require 2 x 14mm, 2 x 17mm and 2 x 19mm combination spanners, you may also find it beneficial to have a soft-headed hammer and perhaps an adjustable spanner handy as this may help.

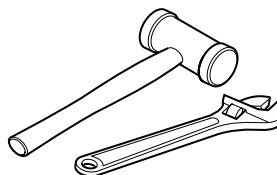

Prepare the Work Area

It is important that you assemble your product in a clean, clear, uncluttered area. This will enable you to move around the product while you are fitting components and will reduce the possibility of injury during assembly.

Work with a Friend

You may find it quicker, safer and easier to assemble this product with the help of a friend as some of the components may be large, heavy or awkward to handle alone.

Open the Carton.

Carefully open the carton that contains your product, taking note of the warnings printed on the carton to ensure that the risk of injury is reduced. Be aware of sharp staples that may be used to fasten the flaps as these may cause injury. Be sure to open the carton the right way up, as this will be the easiest and safest way to remove all the components.

Unpack the Components

Carefully unpack each component, checking against the parts list that you have all the necessary parts to complete the assembly of your product.

Please note that some of the parts may be pre-fitted to major components, so please check carefully before contacting our CUSTOMER SUPPORT team.

In any event, please do not return the product to your retailer before contacting us first.



Safety

Before you undertake any programme of exercise that will increase cardiovascular activity please be sure to consult with your doctor. Frequent strenuous exercise should be approved by your doctor and proper use of your product is essential. Please read this manual carefully before commencing assembly of your product or starting to exercise.

- * Please keep all children away from exercise products when in use. Do not allow children to climb or play on them when they are not in use.*
- * For your own safety, always ensure that there is at least 1 Metre of free space in all directions around your product while you are exercising.*
- * Regularly check to see that all nuts, bolts and fittings are securely tightened. Periodically checking all moving parts for obvious signs of wear or damage.*
- * Clean only with a damp cloth, do not use solvent cleaners. If you are in any doubt, do not use your product, but contact CUSTOMER SUPPORT by any of the means listed on the opposite page.*
- * Before use, always ensure that your product is positioned on a solid, flat surface. If necessary, use a rubber mat underneath to reduce the possibility of slipping in use.*
- * Always wear appropriate clothing and footwear such as training shoes when exercising. Do not wear loose clothing that could become caught or trapped during exercise.*

Storage and Use

Your product is intended for use in clean dry conditions. You should avoid storage in excessively cold or damp places as this may lead to corrosion and other related problems that are outside our control.

Weight Limit

*Your product is suitable for users weighing:
275LBS / 19.6 Stones / 125KG or less.*



Warning

If any part of your product becomes damaged, broken or badly worn do not use the equipment until the defective parts have been replaced

Conformity

*This product conforms to:
BS EN ISO 20957-1 and BS EN 957-2 Class (H) - HOME USE - Class (C).
It is NOT suitable for therapeutic purposes.*



Exercising Information

Beginning

*How you begin to exercise will vary from person to person. If you have not exercised for a long period of time, have been inactive for a while, or are severely overweight you **MUST** start slowly, increasing your exercise time gradually, by perhaps only a few minutes for each session per week.*

Combine a carefully structured nutritious diet with a simple but effective exercise routine and this can help make you feel better, look better and will almost certainly enable you to enjoy life more.

Aerobic Fitness

Aerobic exercise is simply defined as any sustained activity that increases the supply of oxygen to your muscles via the blood pumped by your heart. With regular exercise, your cardiovascular system will become stronger and more efficient. Your recovery rate i.e. the time taken for your heart to reach its normal resting level, will also decrease.

Initially you may only be able to exercise for a few minutes each day. Do not hesitate to breathe through your mouth should you need more oxygen. Use the "talk test". If you cannot carry on a conversation while exercising, you are working too hard! However, aerobic fitness will be gradually built up with regular exercise, over the next six to eight weeks.

Do not be discouraged if it takes longer than this to begin to feel less lethargic, everyone is different and some will achieve their targets quicker than others. Work at your own, comfortable pace and the results will come. The better your aerobic fitness the harder you will have to work to stay in your target zone.



Exercising Information

Warm Up

A successful exercise programme consists of three parts, Warm Up, Aerobic Exercise and Cool Down. Never start a training session without warming up. Never finish one without cooling down correctly. Perform between five and ten minutes of stretching before starting your workout to prevent muscle strains, pulls and cramps.

Aerobic Exercise Session

Those new to exercise should exercise no more than every other day to start with.

As your fitness level increases, increase this to 2 in every 3 days.

When you are comfortable with your routine, exercise for 6 days per week. Always take at least one day off per week.

Exercising in your Target Zone

To ensure that your heart is working in its exercise target zone, you need to be able to take your pulse. If you do not have a pulse monitor (either from the product you are using or a proprietary independent unit) you will need to locate the pulse in your carotid artery. This is situated in the side of the neck and can be felt by using the index and middle fingers. Simply count the number of beats you feel in 10 seconds and then multiply by six to get your pulse rate. This should be taken before you start to exercise for easy reference.



Note

Incorrect or excessive training may damage your health. Please read the exercise information first.

People who have a greater aerobic fitness, have a lower resting pulse level and will also be able to exercise with a higher pulse level.

Target Zone

To determine your target zone, see the chart opposite. If you are new to exercise and by definition unfit, refer to the left column. If you exercise regularly and have good aerobic fitness, refer to the right column.

| USERS AGE (Years) | UNCONDITIONED TARGET ZONE - A (Beats per Minute) | CONDITIONED TARGET ZONE - B (Beats per Minute) |
|---------------------------------|--|--|
| 20-24 | 145 - 165 | 155 - 175 |
| 25-29 | 140 - 160 | 150 - 170 |
| 30-34 | 135 - 155 | 145 - 165 |
| 35-39 | 130 - 150 | 140 - 160 |
| 40-44 | 125 - 145 | 135 - 155 |
| 45-49 | 120 - 140 | 130 - 150 |
| 50-54 | 115 - 135 | 125 - 145 |
| 55-59 | 110 - 130 | 120 - 140 |
| 60 and over | 105 - 125 | 115 - 135 |



Exercising Information

Cool Down

To decrease fatigue and muscle soreness, you should also cool down by walking at a slow relaxed pace for a minute or so, to allow your heart rate to return to normal.

Warm Up and Cool Down Exercises

Hold each stretch for a minimum of ten seconds and then relax. Repeat each stretch two or three times. Do this before your Aerobic Exercise session and also after you have finished.

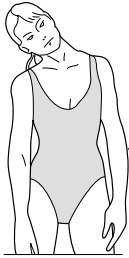

Head Roll

Rotate your head to the right for one count, feeling a slight pull on the left side of your neck. Next, rotate your head back for one count, stretching your chin. Then rotate your head to the left for one count, feeling a slight pull on the right side of your neck. Lastly, drop your head to your chest for one count. Repeat 2 to 3 times.

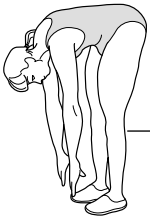

Toe Touch

Slowly bend forward from your waist, letting your back and shoulders relax as you lower your trunk. Gently stretch down as far as is comfortable and hold for 10 seconds.



Shoulder Lift

Rotate and lift your right shoulder up towards your ear for one count. Relax then repeat for the left shoulder. Repeat 3 - 4 times.

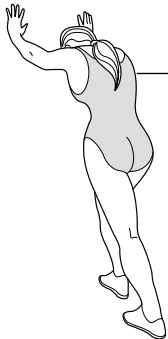

Calf / Achilles Stretch

Turn towards the wall and place both hands on it. Support yourself with one leg while the other is placed behind you with the sole flat on the floor. Bend the front leg and lean towards the wall, keeping the rear leg straight so that the calf and Achilles tendon are stretched hold for 5 seconds. Repeat with the other leg. Repeat 2 - 3 times.



Side Stretch

Open both arms to the side and gently lift them above your head. Reach your right arm as high as you can for one count, gently stretching the muscles of the stomach and lower back. Repeat the action with your left arm. Repeat 3 - 4 times.



Inner Thigh Stretch

Sit on the floor and pull your legs toward your groin, the soles of your feet together. Hold your back straight and lean forward over your feet. Tighten the thigh muscles and hold for 5 seconds. Release and repeat 3 - 4 times.

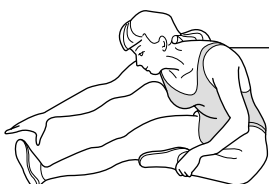

Hamstring Stretch

Sit on the floor with your right leg extended and place your left foot flat against the right inner thigh. Stretch forward toward the right foot and hold for 10 seconds. Relax and then repeat with the left leg extended. Repeat 2 - 3 times.



Exercising Information

Basic Aerobic Training Programme

For your basic Aerobic Exercise routine we suggest that you try the following. Remember, breathe correctly, exercise at your own pace and do not over-train as injury may result.

Week 1 & 2

Warm Up 5 - 10 Minutes
Cool Down 5 Minutes

Exercise 4 minutes at 'A'
Rest 1 minute
Exercise 2 minutes at 'A'
Exercise slowly 1 minute

Week 3 & 4

Warm Up 5 - 10 Minutes
Cool Down 5 Minutes

Exercise 5 minutes at 'A'
Rest 1 minute
Exercise 3 minutes at 'A'
Exercise slowly 2 minutes

Week 5 & 6

Warm Up 5 - 10 Minutes
Cool Down 5 Minutes

Exercise 6 minutes at 'A'
Rest 1 minute
Exercise 4 minutes at 'A'
Exercise slowly 3 minutes

Week 7 & 8

Warm Up 5 - 10 Minutes
Cool Down 5 Minutes

Exercise 5 minutes at 'A'
Exercise 3 minutes at 'B'
Exercise 2 minutes at 'A'
Exercise slowly 1 minute
Exercise 4 minutes at 'A'
Exercise slowly 3 minutes

Week 9 & beyond

Warm Up 5 - 10 Minutes
Cool Down 5 Minutes

Exercise 5 minutes at 'A'
Exercise 3 minutes at 'B'
Exercise 2 minutes at 'A'
Exercise slowly 1 minute
Repeat entire cycle 2 or 3 times

This is only a suggested programme and may not suit every individual's needs.

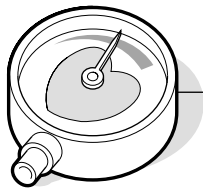

Exercising Information

GETTING STARTED

You will often read about terms referring to exercise that may be confusing. Below are some of the definitions that are regularly used.

Repetition - Commonly referred to as 'REPS'.

This is a complete movement from start to finish.

Set - This is a complete number of consecutive repetitions.

i.e. 1 set of 10 reps.

Speed of Motion - This is the relative speed of movement for each rep.

Fast is considered as 1 rep / second. Medium is 1 rep / 2 seconds. Slow is 1 rep / 4 seconds.

Intensity - How 'hard' the exercise feels.

Low Intensity = easy exercise. High Intensity = hard exercise.

TRAINING PROGRAMMES

You will achieve fast results, gaining a trimmer, fitter body if you follow these general rules.

- * Exercise regularly - do not skip workouts as consistency is the first key to success.
- * Do not be afraid perspire a little. This is a sign that you are working your body hard enough to give fast results. You will find 'hard' exercise enjoyable.
- * Set yourself realistic goals. Do not be over-ambitious. Plan your workouts to concentrate on specific body areas. Start slowly and gradually increase the intensity, reps and sets.

BEGINNERS PROGRAMME

This is a short suggested programme which we suggest you use for no more than 3 weeks, to be ideally performed every other day, but certainly not more than 4 times during the week.

This suggested routine is specifically for beginners or those who have not exercised for a considerable time. The programme is designed to provide general improvement in muscle tone, strength, flexibility and co-ordination.

As a beginner, you should start with no more than 2 sets of 6 exercises for the following reps on each of the Gym's training stations.

10 REPS - BENCH PRESS followed by LAT PULLDOWNS

5 REPS - PEC DEC

10 REPS - LOW PULLEY PULL UPS

10 REPS - LEG EXTENSIONS followed by LEG CURLS

- * Your rest interval between each set of reps should be 1 minute.
- * You should perform 2 SETS of each exercise.
- * Your exercise pace should be SLOW to MEDIUM.
- * The resistance (weight) settings should be in positions 1 - 3.
- * This exercise programme should take you approximately 20 minutes.
- * Follow this exercise programme with 5 minutes of proper cool down exercises.



Exercising Information

INTERMEDIATE EXERCISE

This is a slightly longer programme which we suggest you use for the next 6 - 8 weeks, to be ideally performed not more than 5 times during the week.

This suggested routine is specifically for intermediate users or those that are familiar with exercise routines. The programme is designed to increase muscle definition, build strength, aid flexibility and co-ordination.

The increase in exercise intensity and speed of repetitions is key to your success at this stage. For intermediate exercise we recommend 3 - 4 sets of 8 exercises for the following reps on each of the Gym's training stations.

15 REPS - BENCH PRESS followed by LAT PULLDOWNS

10 REPS - PEC DEC

15 REPS - LOW PULLEY PULL UPS

15 REPS - LEG CURLS

15 REPS - LEG EXTENSIONS

- * Your rest interval between each set of reps should be 1 minute.
- * You should perform 3 - 4 SETS of each exercise.
- * Your exercise pace should be MEDIUM to FAST.
- * The resistance (weight) settings should be in positions 3 - 6.
- * This exercise programme should take you approximately 35 - 40 minutes.
- * Follow this exercise programme with 5 minutes of proper cool down exercises.

ADVANCED TRAINING

This is an open-ended programme, ideally performed not more than 4 times during the week, preferably on alternate days.

This suggested routine is specifically for advanced users or those that are familiar with exercise routines. The programme is designed to increase muscle mass and build strength.

The increase in exercise intensity, resistance levels and speed of repetitions is key to your on going success.

For advanced training we recommend 4 sets of the 9 exercises for the following reps on each of the Gym's training stations. However at this stage you may want to concentrate on specific body parts, so as you are now fully familiar with the workings of your Gym you should be able to structure an exercise programme to suit your own individual needs. Any specific advice should be sought through specialist books.

20 REPS - BENCH PRESS followed by LAT PULLDOWNS

15 REPS - PEC DEC

15 REPS - LOW PULLEY PULL UPS

15 REPS - LEG CURLS

20 REPS - LEG EXTENSIONS

15 REPS - LEG PRESS

10 SLOW REPS - 2 SETS - SIT UPS

- * Your rest interval between each set of reps should be 1 minute.
- * You should perform 4 SETS of each exercise.
- * Your exercise pace should be MEDIUM to FAST.
- * The resistance (weight) settings should be in positions 4 - 8.
- * This exercise programme should take you approximately 40 - 50 minutes.
- * Follow this exercise programme with 5 minutes of proper cool down exercises.

Assembly

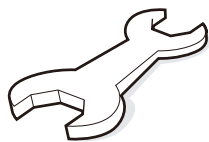

Carefully unpack each component, checking against the parts list that you have all the necessary parts to complete the assembly of your gym.

Beny Sports Co. UK Ltd.
Unit 8 Riparian Way,
The Crossings Business Park,
Cross Hills,
West Yorkshire.
BD20 7BW

Please note that some of the parts may be pre-fitted to major components, so please check carefully before contacting our CUSTOMER SUPPORT team.

In any event, please do not return the product to your retailer before contacting us first.

Tel:- 0800 3 101 202 or
+44 (0) 1535 637711
Email:- support@benysports.co.uk

CUSTOMER SUPPORT is open from 9.00am to 5.00pm from Monday to Friday

Please note that as part of our production checking and for your convenience, all tube caps where necessary have been fitted in the pre-packing stage.

Stage A.

1). Lay the Rear Stabiliser (20) flat on the floor and lay the Base Frame U Bracket (22) onto the centre of the Rear Stabiliser, making sure the loop is facing the rear of the gym. Place the 2 Weight Guide Tubes (21) into the 2 outer holes in the U Bracket.

2). Connect the Main Base (1) and the Rear Stabiliser together using 2 x M10 x 60mm Hex Bolts (28), 4 x M10 Flat Washers (38) and 2 x M10 Nylon Locknuts (35).

3). Lay the Footplate (18) onto the front of the Main Base and lock in position with the Footplate Lock Pin (43).

4). Slide the 2 Rubber Bumpers (62) onto the Weight Guide Tubes followed by the 6 Weight Plates (60).

5). Take the Selector Shaft (16) and fit the Selector Shaft Bush (58) and Selector Shaft Pin (46) as per inset "A". Slide the Top Plate (59) onto the Weight Guide Tubes and locate the Selector Shaft in position, setting the Top Plate onto the top Weight Plate. Use the Weight Selector Pin (41) to select the desire weight.

Tip: To lock the weight stack simply place the Weight Selector Pin (41) into the welded bracket on the top of the Base Frame U Bracket (22) which will lock the Selector Shaft (16).

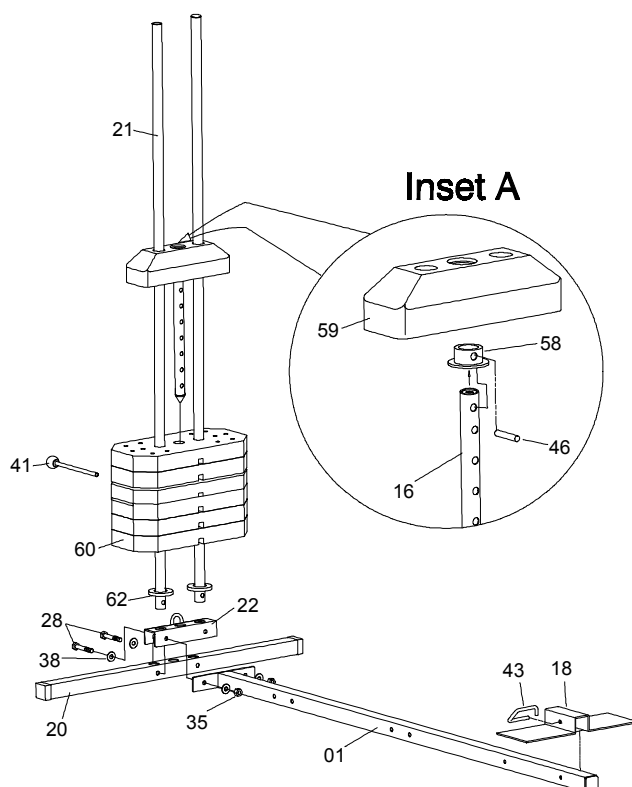

Note

Do NOT FULLY TIGHTEN any Bolts, Nuts or Fittings at this stage unless specifically instructed to do so.

Please ensure when finally tightening all Bolts that the locking ring in the Locknut is fully engaged as (2) below.

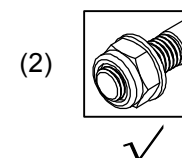
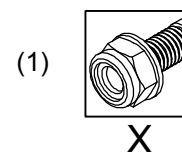

Assembly

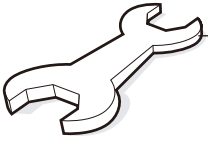

Stage B.

6). Fit the Rear Upright (2) to the Main Base using 2 x M10 x 55mm Hex Bolts (27), 4 x M10 Flat Washers (38) and 2 x M10 Nylon Locknuts (35).

7). Fit the Front Upright (3) to the Main Base using 2 x M10 x 55mm Hex Bolts (27), 4 x M10 Flat Washers (38) and 2 x M10 Nylon Locknuts (35).

8). Connect the Rear Upright and the Front Upright together with the Lower Cross Beam (10) using 4 x M10 x 55mm Hex Bolts (27), 8 x M10 Flat Washers (38) and 4 x M10 Nylon Locknuts (35).

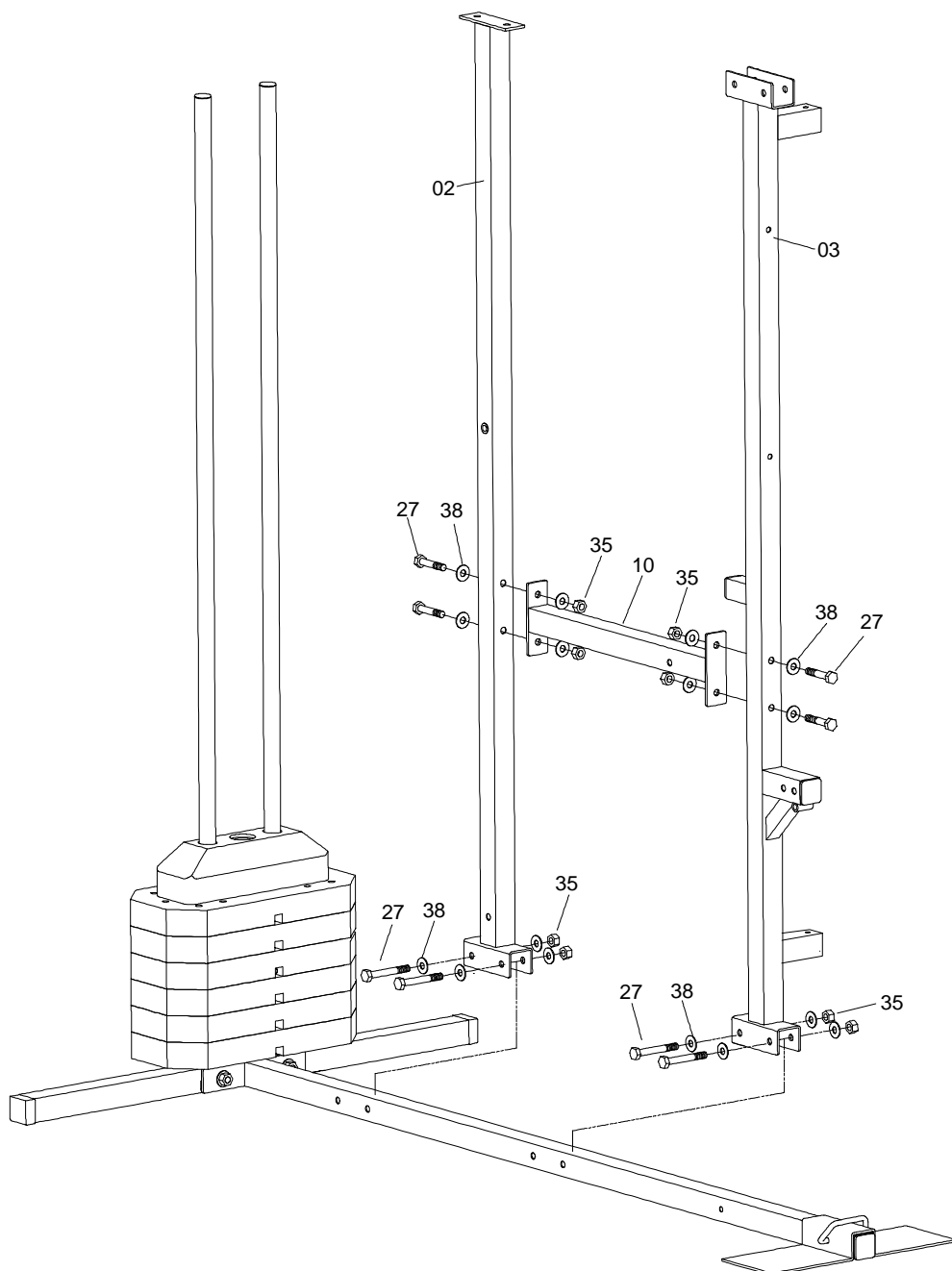

Assembly

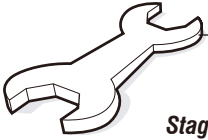

Stage C.

9). Lay the Upper Cross Beam (6) onto the 2 assembled Uprights and connect the Front Upright to the Top Cross Beam using 2 x M10 x 55mm Hex Bolts (27), 4 x M10 Flat Washers (38) and 2 x M10 Nylon Locknuts (35).

10). Connect the Rear Upright to the Upper Cross Beam using 2 x M10 x 55mm Hex Bolt (27), 4 x M10 Flat Washers (38) and 2 x M10 Nylon Locknuts (35).

11). Remove the 2 x M10 x 20mm Hex Bolts (25), 2 x M10 Washers (38) from inside the top of the Weight Guide Tubes (21). Connect the top of the Weight Guide Tubes to the rear of the Upper Cross Beam using the 2 x M10 x 20mm Hex Bolts (25), 2 x M10 Washers (38) previously removed.

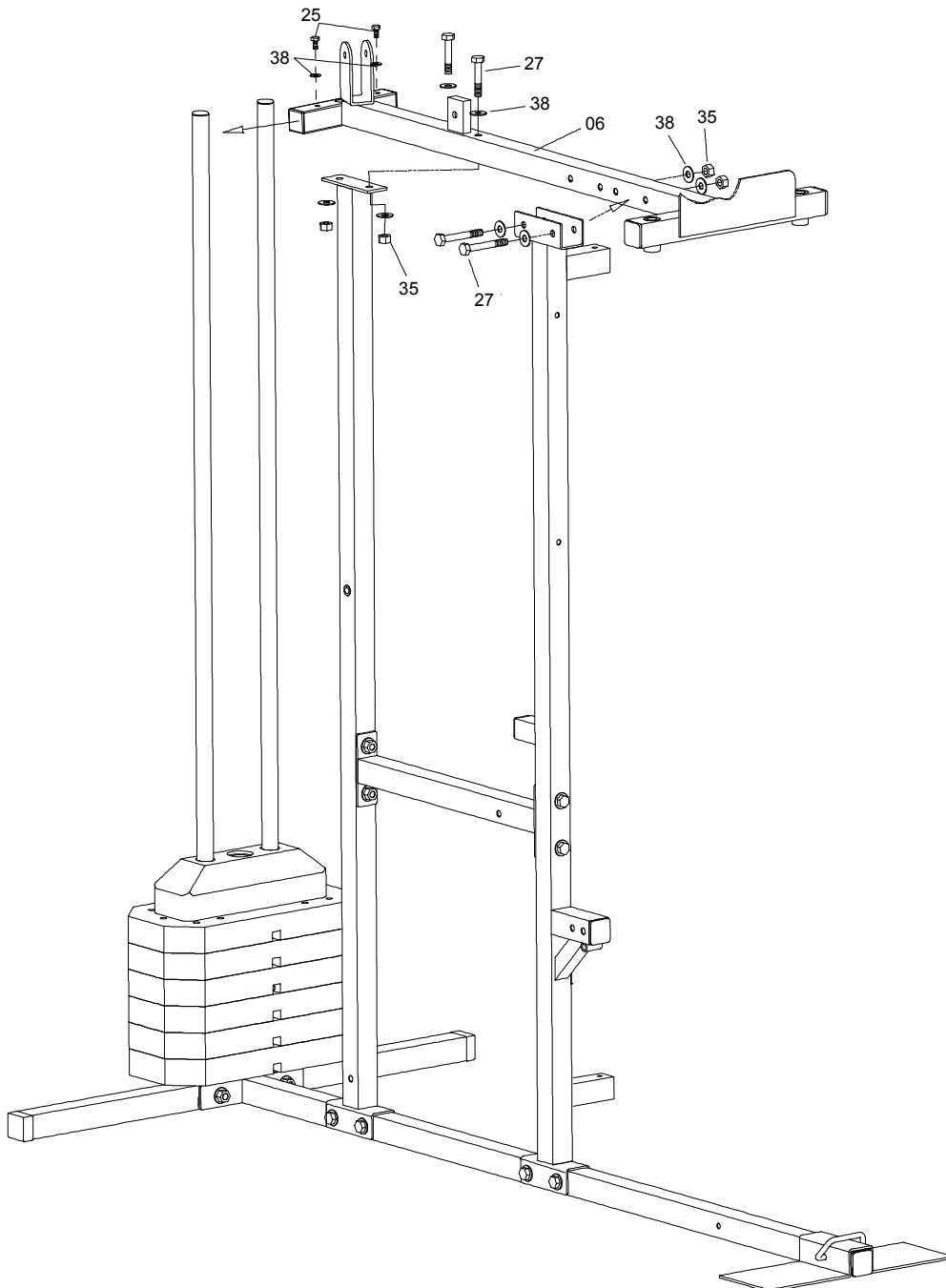

Assembly

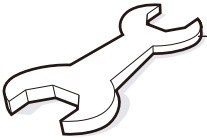

Stage D.

12). Fit the Chest Press Bar (11) to the Rear Upright with 1 x M10 x 65mm Hex Bolt (29), 2 x M10 Flat Washers (38) and 1 x M10 Nylon Locknut (35).

13). Fit both Chest Press Arms (9) to the Chest Press Bar using 2 x M10 x 130mm Hex Bolts (32), 4 x M10 Flat Washers (38) and 2 x M10 Nylon Locknuts (35).

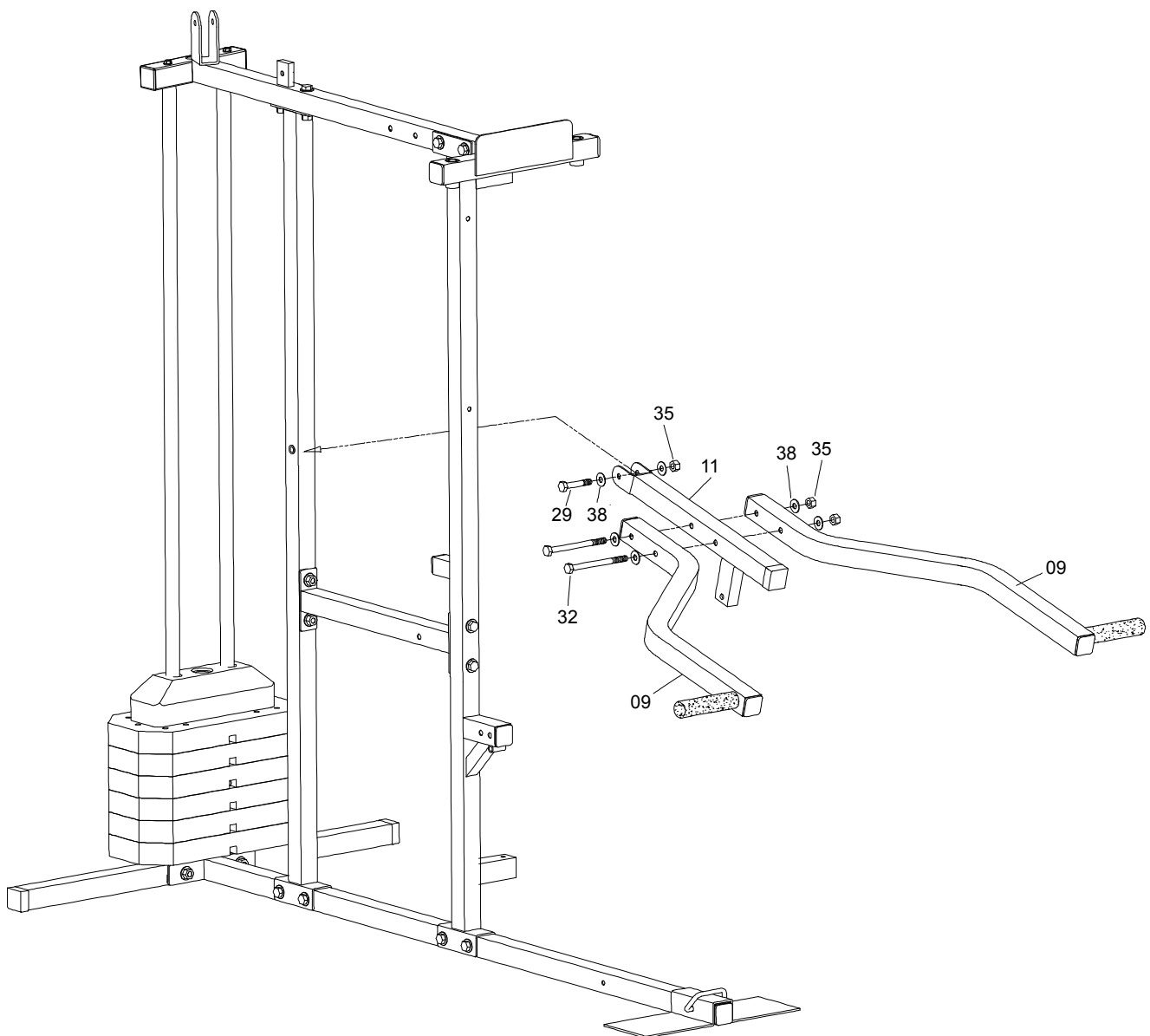

Assembly

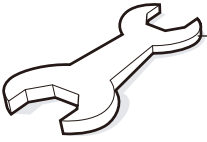

Stage E.

14. Fit the Lat Bar Frame (5) to the Upper Cross Beam using 2 x M10 x 55mm Hex Bolts (27), 4 x M10 Flat Washers (38) and 2 x M10 Nylon Locknuts (35).

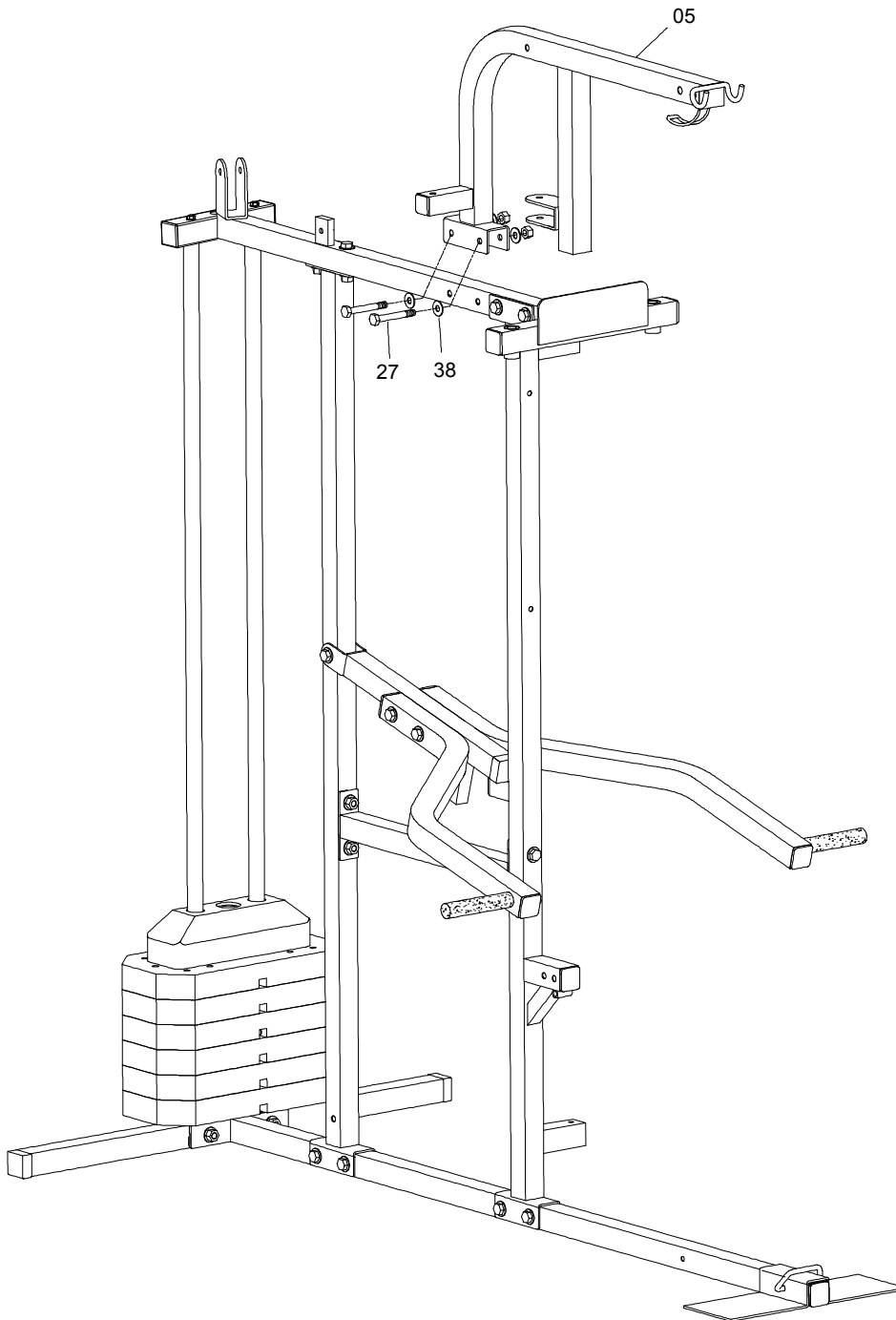

Assembly

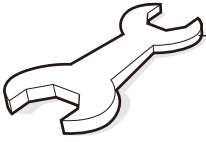

Stage F.

Note: Four Oil Bushings (63) have been pre-assembled into the Upper Cross Beam (6).

15). Fit each Pec Arm to the Upper Cross Beam using 1 x M12 Flat Washer (40), 1 x M12 Nylon Locknut (36) and slide 2 x Pec Deck Foam Pads (65) onto each Pec Deck Arm (7 & 8).

Note: - Tighten sufficiently to ensure that all free-play is removed but that it is still possible to rotate the Pec Arms.

Tip: To lock the Pec Arms during the bench press exercises, please fit the Pec Deck Arm Lock Pins (42A) into the inner holes in each Pec Arm. To store the pins when using the Pec Assembly simply place in the 2 holes marked "X" in the front frame.

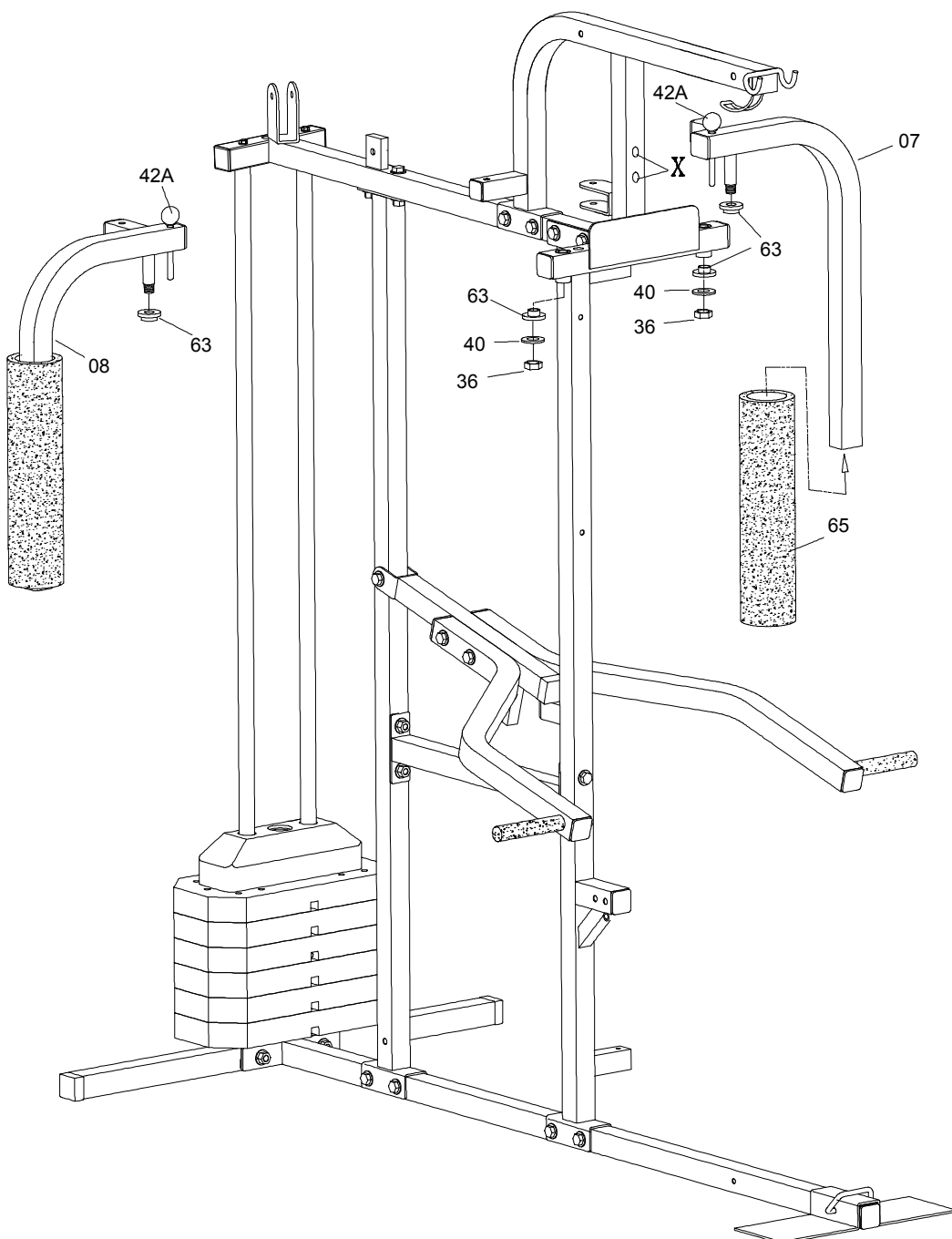

Assembly

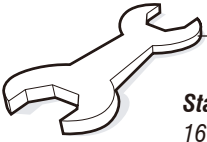

Stage G.

16). Fit the Backrest Support (4) to the bracket on the Front Upright using 1 x M10 x 60mm Hex Bolt (28), 2 x M10 Flat Washers (38) and 1 x M10 Nylon Locknut (35).

Note: - This **MUST** be fitted into the **FRONT** hole in the bracket. Fit the Backrest Lock-Pin (42) into the **REAR** hole in the bracket to lock the Backrest Support in place.

17). Fit the Leg Extension Upright (12) to the Front Stabiliser (19) using 2 x M10 x 55mm Hex Bolt (27), 4 x M10 Flat Washers (38) and 2 x M10 Nylon Locknut (35). Fit the Leg Extension Upright (12) to the front of the Backrest Support using 1 x M10 x 55mm Hex Bolt (27), 2 x M10 Flat Washers (38) and 1 x M10 Nylon Locknut (35). Locate 1 x M8 x 55mm Carriage Bolt (33) into the top hole in the front of the Backrest Support and lock the Leg Extension Upright in place using 1 x M8 Knob (50), fitted from underneath.

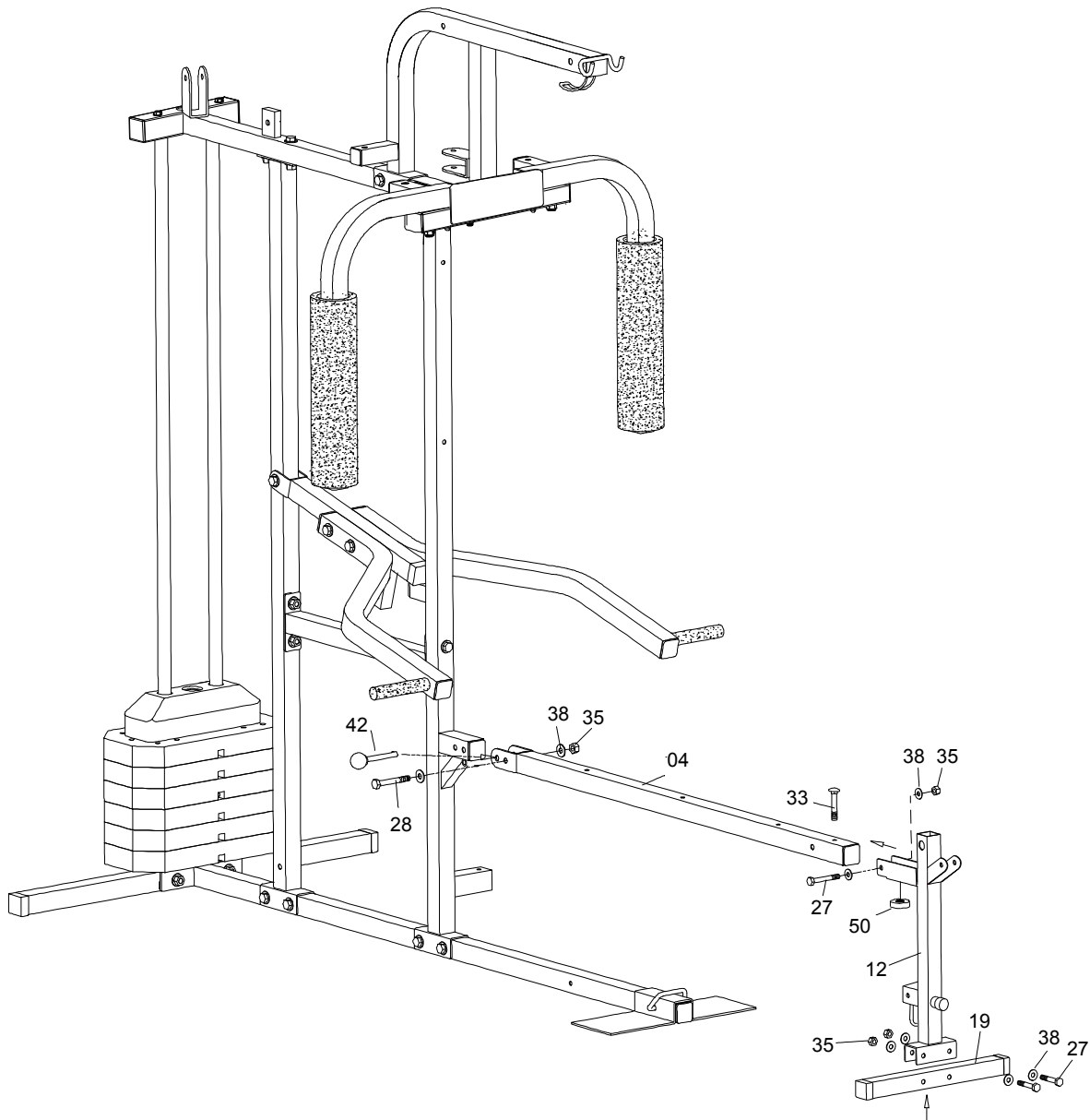

Assembly

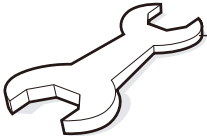

Stage H.

18). Slide a Leg Extension Foam Pad (66) onto one end of both Pad Bars (23). Slide one Pad Bar into the Leg Extension (13) and fit another Leg Extension Foam Pad to the free side. Slide the other Pad Bar into the top hole in the Leg Upright (12) then fit the remaining Leg Extension Foam Pad.

19). Connect the Leg Upright to the Leg Extension using 1 x M10 x 60mm Hex Bolt (28), 2 x M10 Flat Washers (38) and 1 x M10 Nylon Locknut (35).

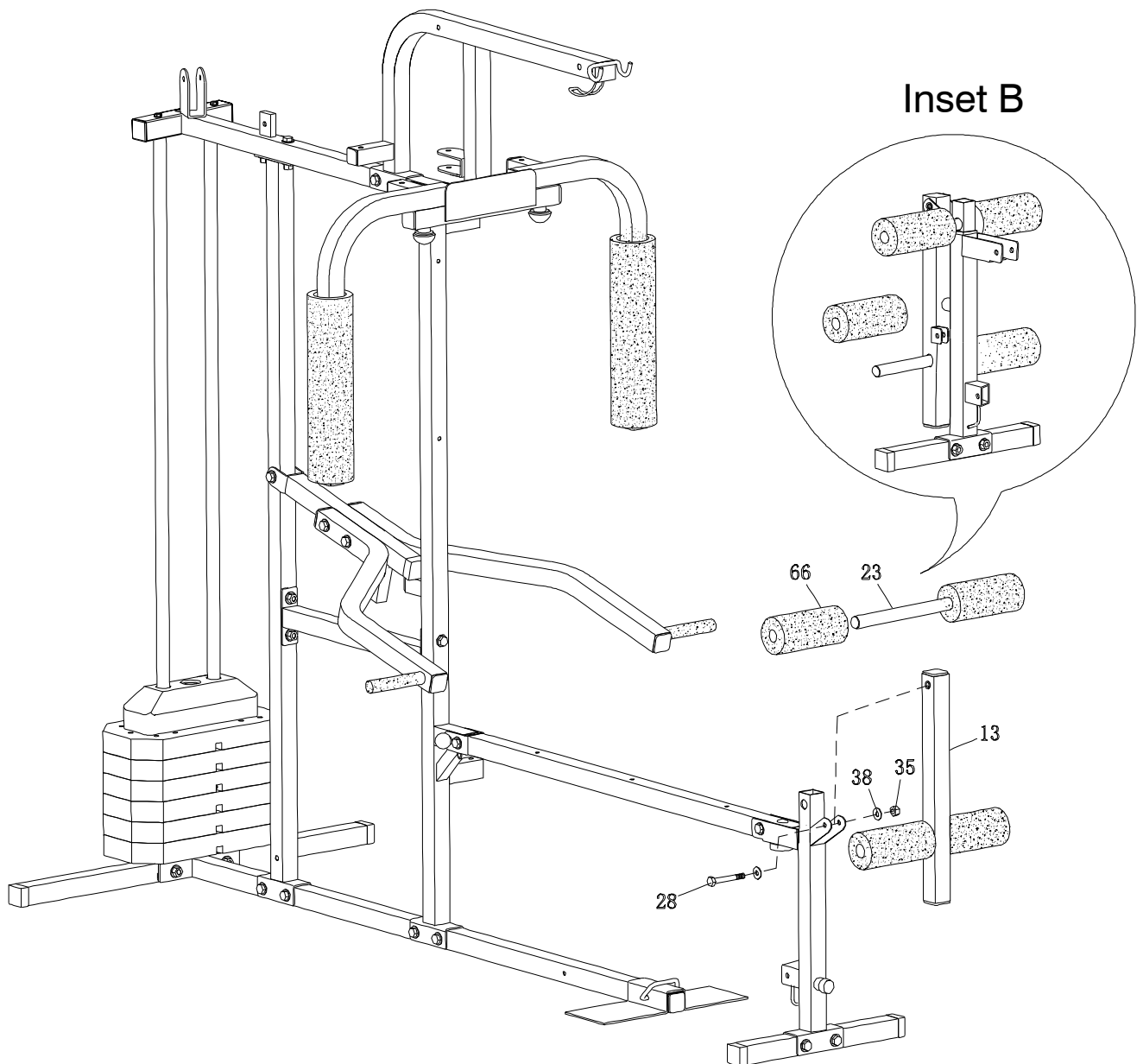

Assembly

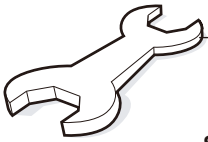

Stage I.

20). Carefully fit the first 13 Pulleys (68) shown on Stage I by using the Bolts, Washers and Nuts shown for each Pulley. You will need the following: -

Part 26 - M10 x 40mm Hex Bolts - Qty 3

Part 31 - M10 x 80mm Hex Bolts - Qty 10

Part 35 - M10 Nylon Locknuts - Qty 14

Part 38 - M10 x 20mm OD Flat Washers - Qty 28

Part 75 - M10 x 38mm OD Flat Washers - Qty 10

Please refer to Figure "A" For the assembly of all Pulleys (except the Pulleys in the U brackets)

Note: - The Auxiliary Pec Pulley Bracket (24) (Inset "C") should be able to rotate when assembled.

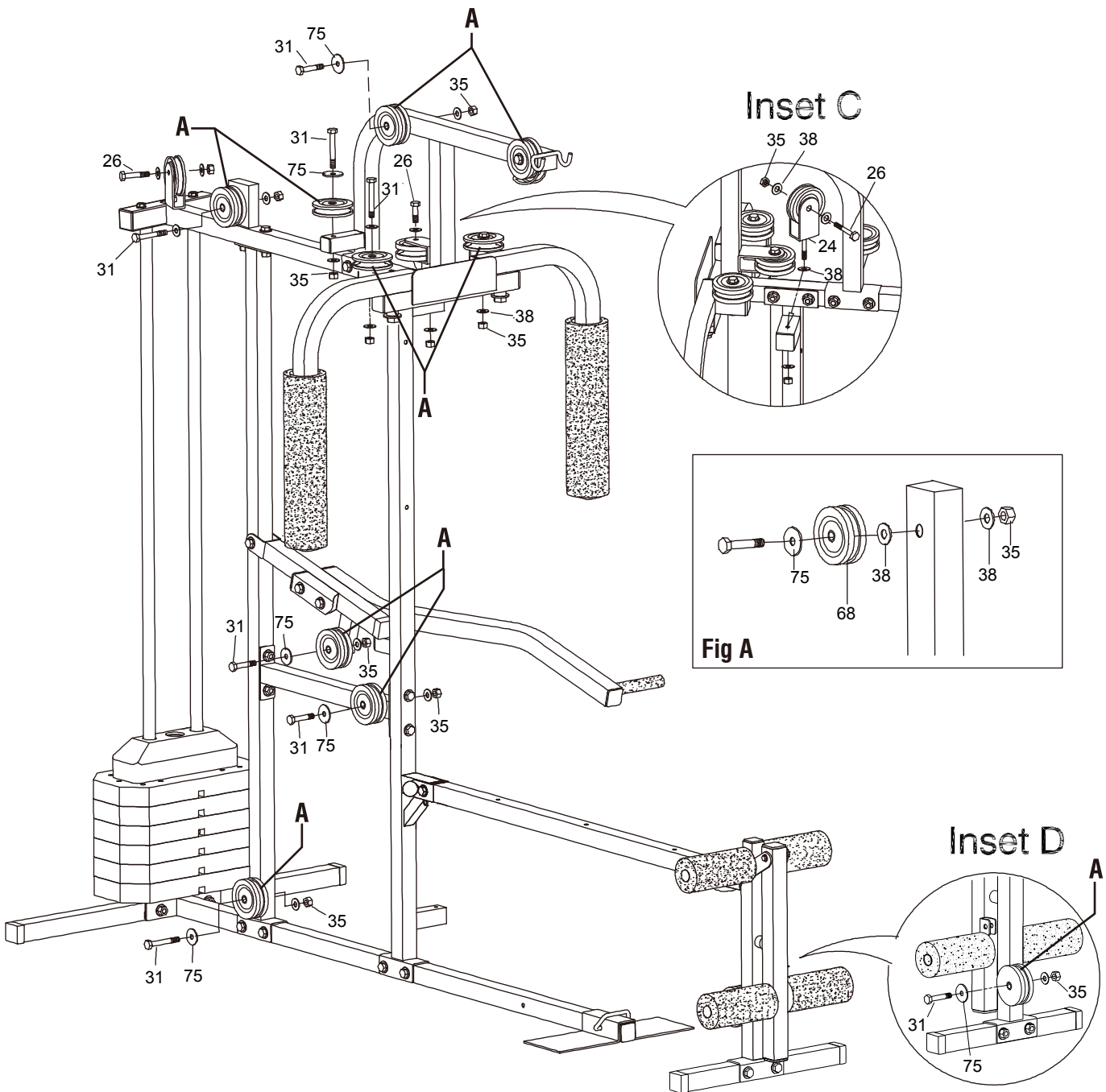

Assembly



Stage J.

21). Fit 1 x Pulley (68) And 2 x Pulley Bearing so the Floating Pulley Bracket (17) (Inset "E"), using 1 x M10 x 40mm Hex Bolt (26), 2 x M10 Flat Washers (38) and 1 x M10 Nylon Locknut (35).

22). Fit the remaining Pulley (68) to the Auxiliary Leg Pulley Bracket (17A) (Inset "F"), using 1 x M10 x 40mm Hex Bolt (26), 2 x M10 Flat Washers (38) and 1 x M10 Nylon Locknut (35). Fit this assembly to the Front Upright near the Backrest Frame - Front Upright fixing bracket using, 2 x M10 Flat Washers (38) and 1 x M10 Nylon Locknut (35).

Note: - The Auxiliary Leg Pulley Bracket should be able to rotate when assembled.

23). Connect one end of the Leg Extension Cable (49) to the bracket on the back of the Leg Extension (Inset "G"), locating the Leg Cable Pin (44) in the position. Fit a Carabina Clip to the other end of this Cable.

24). Take the THREADED end of the Weight Stack Cable (47) and pass it through the Auxiliary Leg Pulley Bracket fitted in Stage J-22 above. Route this cable up the Front Upright and around the Pulleys shown in Inset "H" following the route in Inset "I", over the rearmost Pulley **and down through the hole in the frame** and into the Selector Shaft, securing in place by first fitting the M12 Top Plate Washer (37) then tightening the threaded end of the cable securely in the Selector Shaft.

25). Take the LOOPED end of the Lat Cable (48) and pass it through the Top Lat Bar Bracket, Over the Top Front Lat Pulley, Around the Top Rear Pulley, Down the rear of the Front Upright, Under the Lower Cross Beam Pulley, Over the Chest Press Bar Pulley, Under the Rear Upright Lower Pulley then connect the Carabina clip (45) And Chain (72) to the Lat Cable end with 1 x M8 x 25mm Hex Bolt (73) and 1 x M8 Nylon Locknut (74) & 2 x Washers (39). Fit the Adjuster Chain (72), using the link that reduces overall cable slack and hook onto the Floating Pulley Bracket (17). Once this cable is secure, fit the Lat Bar (15) to the Carabina Clip and position the Lat Bar onto the rest hooks by the Front Lat Pulley.

Note: - To further reduce or increase cable slack in your system you can make fine adjustments by adjusting the bolt on the Weight Stack Cable. Please ensure that at least 30% of the thread on this bolt is screwed into the Selector Shaft.

Assembly

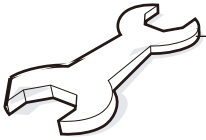

Inset H

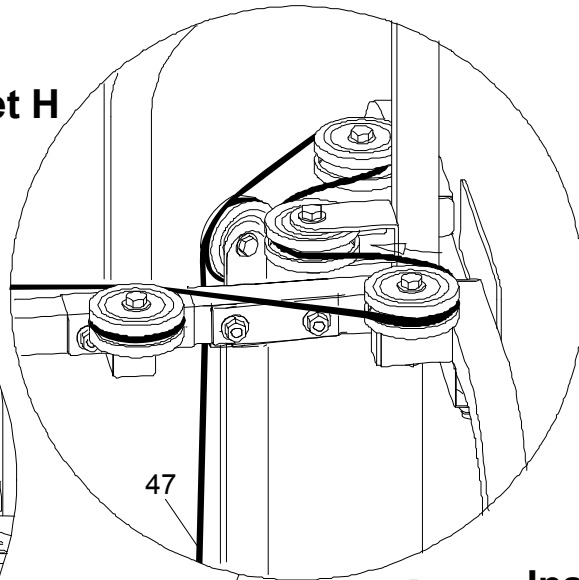

Inset I

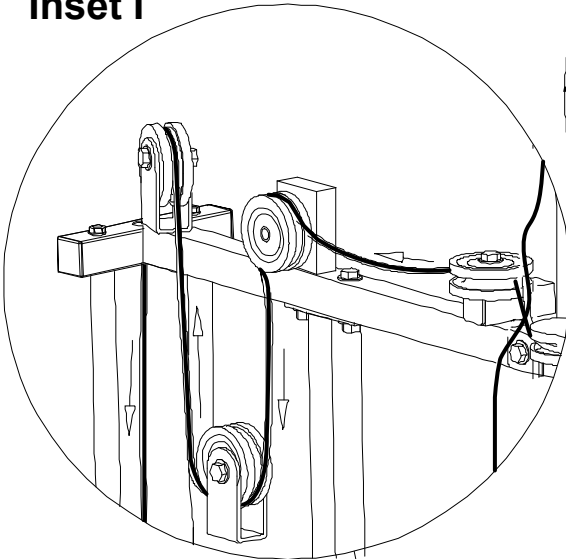

Inset J

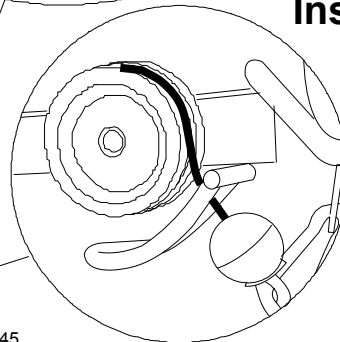

Inset E

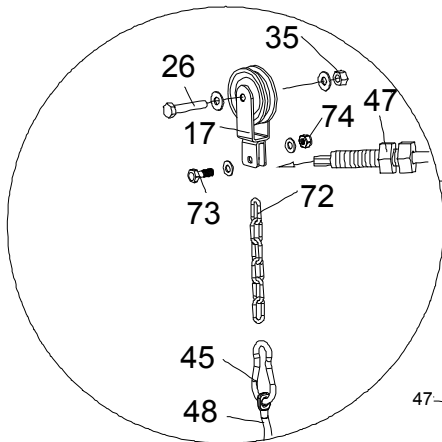

Inset F

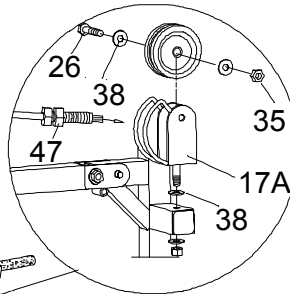

Inset G

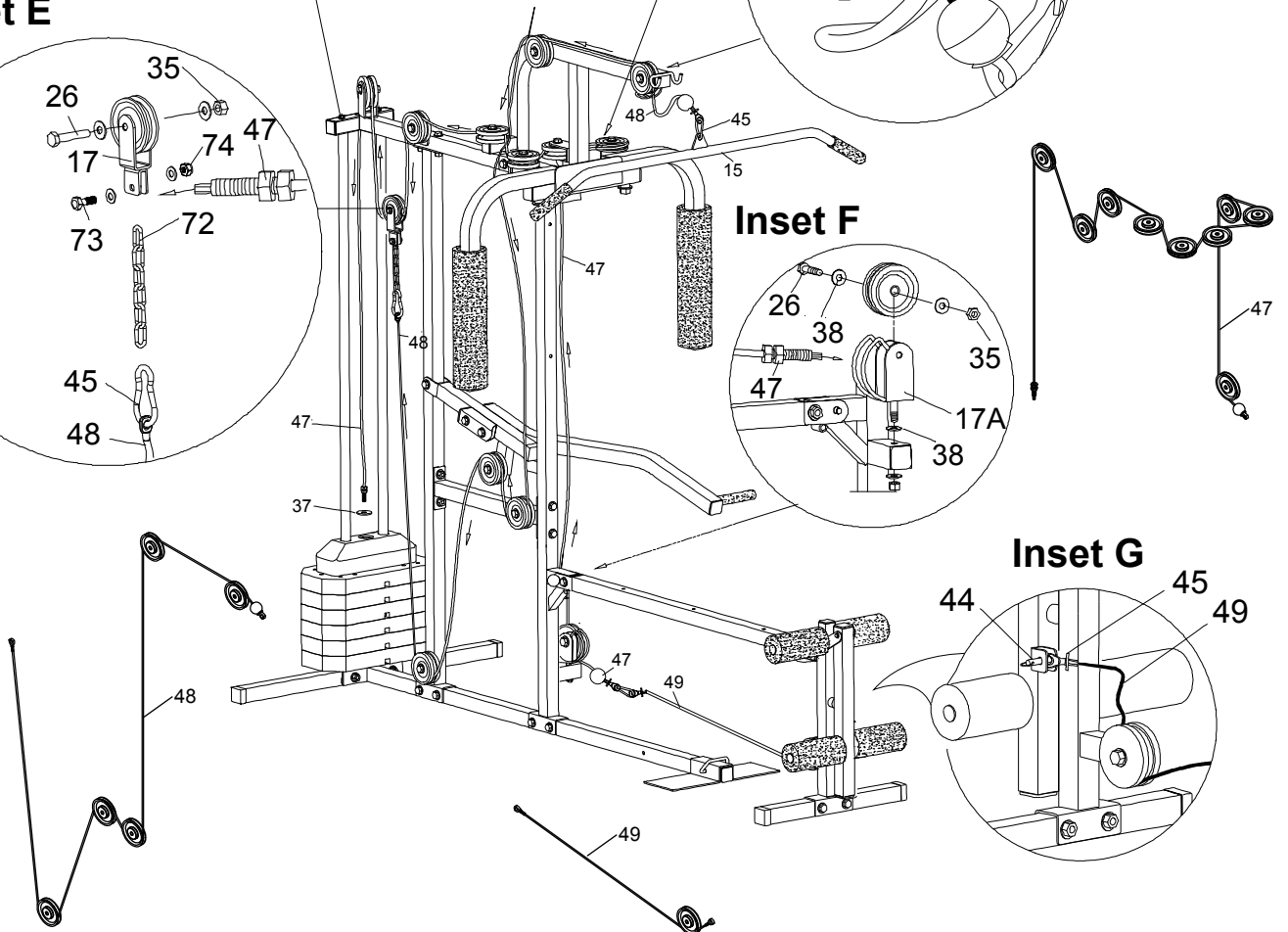
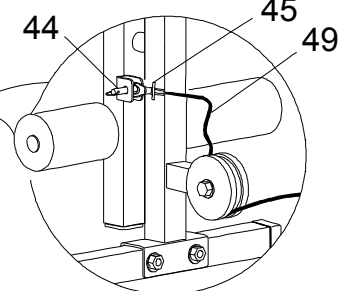

Assembly

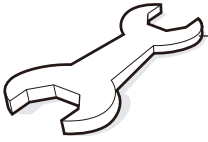

Stage K.

26). Fit the Backrest (70) to the Backrest Support using 3 x M8 x 50mm Hex Head Bolts (34) and 3 x M8 Flat Washers (39)

27). Fit the Seat Back (71) to the Front Upright using 2 x M8 x 50mm Hex Head Bolts (34) and 2 x M8 Flat Washers (39).

FINALLY & BEFORE USING YOUR LAY FLAT HOME GYM DOUBLE CHECK ALL NUTS AND BOLTS FOR SECURITY AND ENSURE CORRECT ROUTING OF THE CABLES AND THAT ALL PULLEYS ARE ABLE TO ROTATE CORRECTLY.

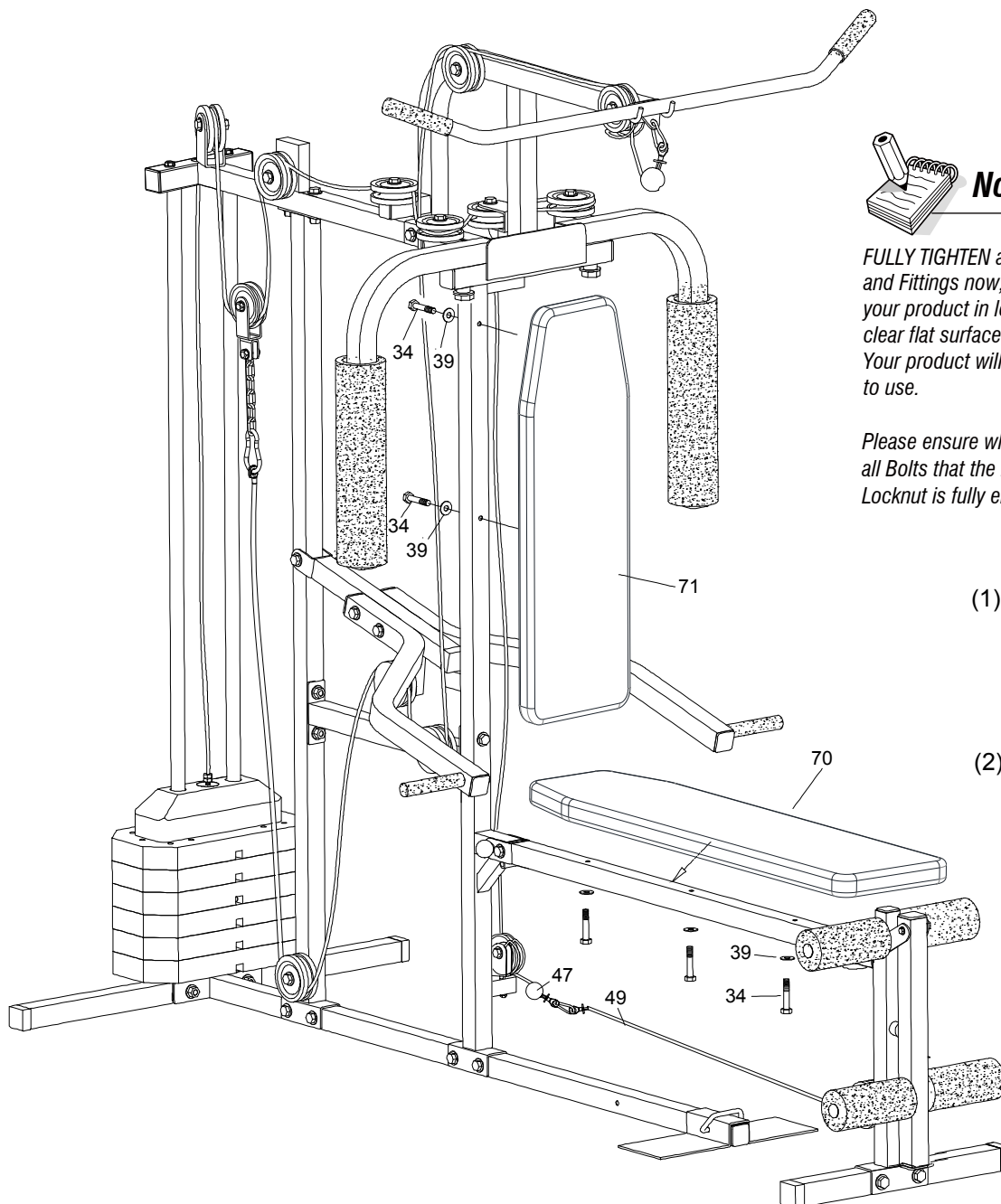

Note

FULLY TIGHTEN all Bolts, Nuts and Fittings now, ensuring that your product is located on a clear flat surface before doing so. Your product will now be ready to use.

Please ensure when finally tightening all Bolts that the locking ring in the Locknut is fully engaged as (2) below.

(1)

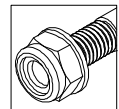

X

(2)

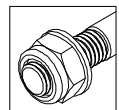

✓

Assembly

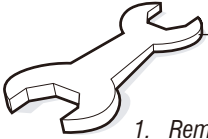

FOLDING THE BENCH FOR STORAGE

1. Remove the M8 Knob (50) fitted to the underside of the Backrest Support (4) at the FRONT by the Leg Extension Upright (12).

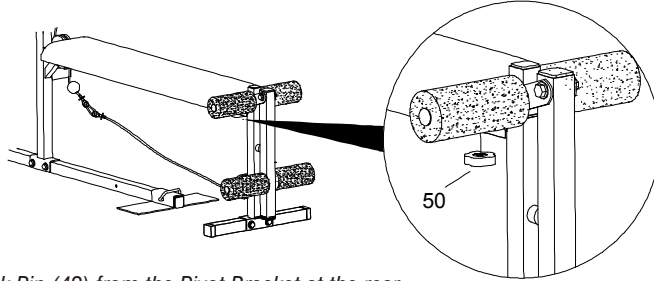

2. Remove the Backrest Lock Pin (42) from the Pivot Bracket at the rear of the Backrest Support (4).

3. Remove the Link Cable (49A) from the Lat Bar Support Hook.

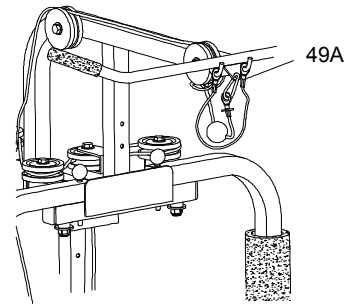
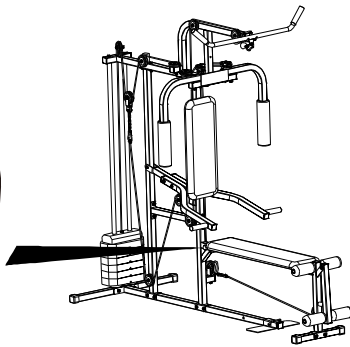
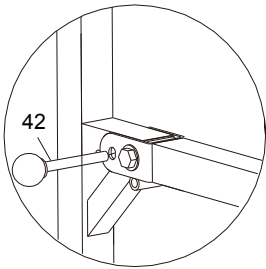

4. Carefully lift the front of the Bench / Backrest then fold the Leg Unit down. Wrap the Link Cable around the Backrest Support as shown and secure the Bench in place, fastening the 2 ends of the Link Cable using the 2 Pec Dec Arm Lock Pins (42A).

5. For added security, re-fit the Backrest Lock Pin (42) from the Pivot Bracket at the rear of the Backrest Support (4), which was removed in Step 2 above.

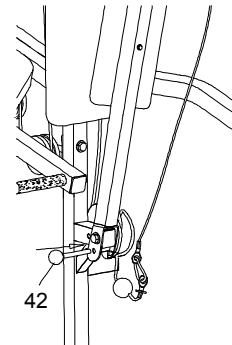
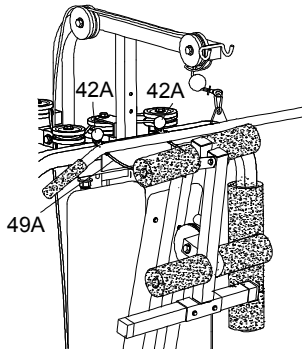

6. To prepare the Gym for use again, carefully reverse the above procedure noting that the upright Backrest will be heavy when released.

7. When your gym is not in use, making sure to place the Weight Selector Pin (41) into the loop on the back of the Base Frame U Bracket (22) which will lock the Selector Shaft (16) to lock all Weight Stacks (60) firmly.

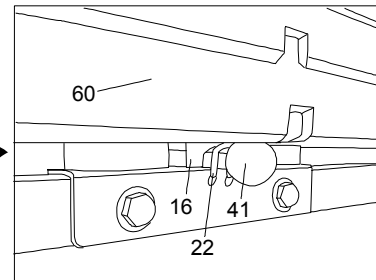
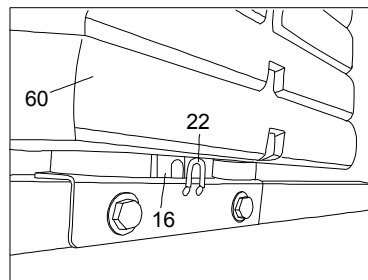
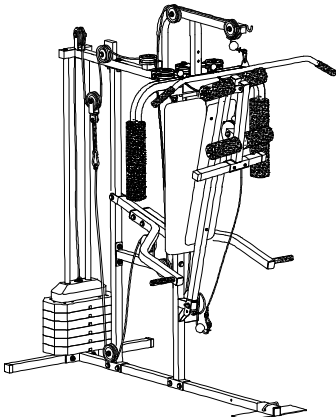

Assembly

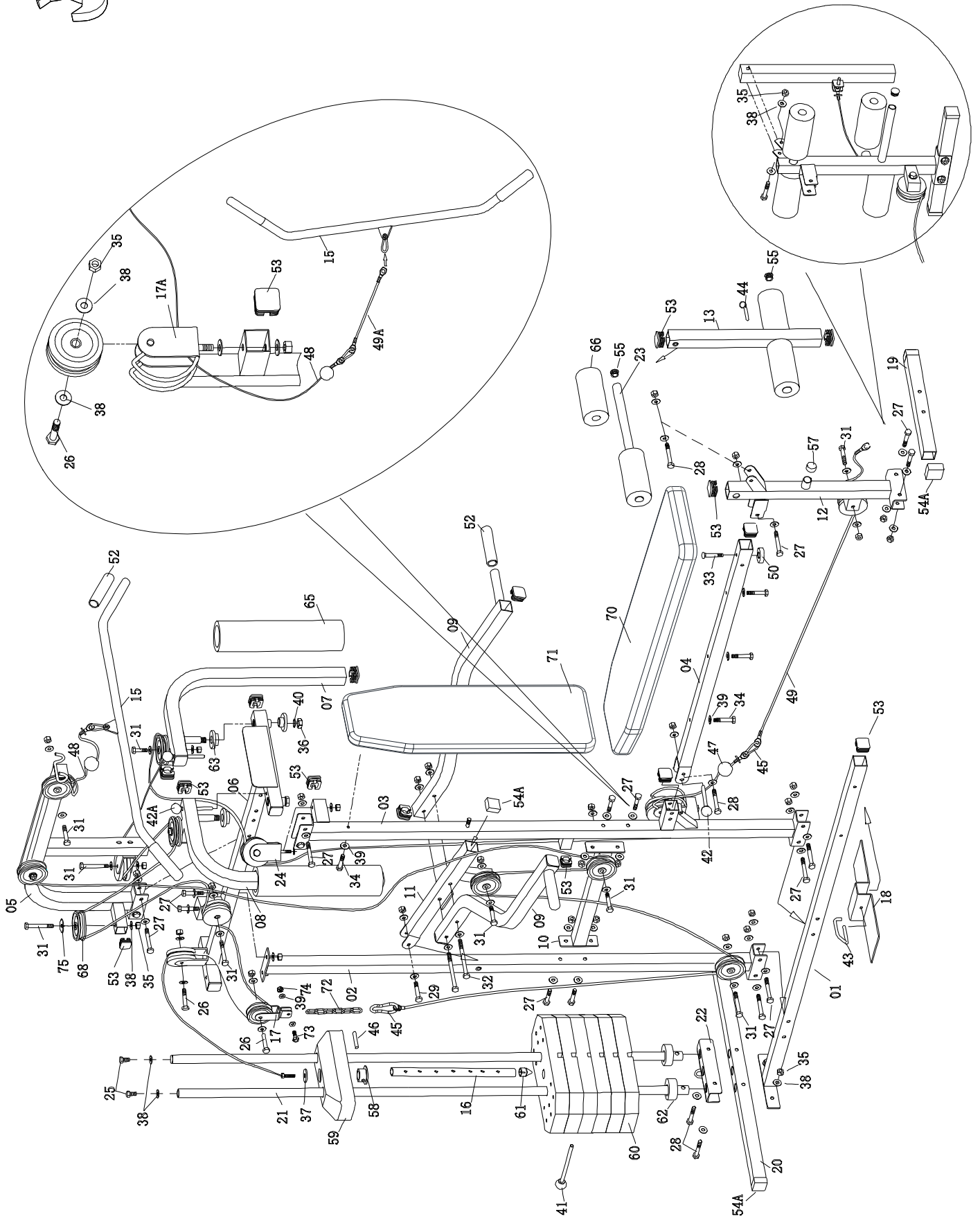
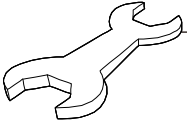

Assembly

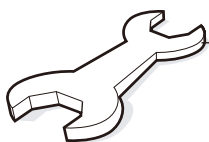

| PART No. | DESCRIPTION | QTY | | | |
|----------|------------------------------|-----|-----|-----------------------------|----|
| 1 | MAIN BASE | 1 | 43 | FOOTPLATE LOCK PIN | 1 |
| 2 | REAR UPRIGHT | 1 | 44 | LEG CABLE PIN | 1 |
| 3 | FRONT UPRIGHT | 1 | 45 | CARABINA CLIPS | 3 |
| 4 | BACKREST SUPPORT | 1 | 46 | SELECTOR SHAFT PIN | 1 |
| 5 | LAT BAR FRAME | 1 | 47 | WEIGHT STACK CABLE (4835mm) | 1 |
| 6 | UPPER CROSS BEAM | 1 | 48 | LAT CABLE (3940mm) | 1 |
| 7 | LEFT PEC DECK ARM | 1 | 49 | LEG EXTENSION CABLE(1090mm) | 1 |
| 8 | RIGHT PEC DECK ARM | 1 | 49A | CABLE (500mm) | 1 |
| 9 | CHEST PRESS ARMS | 2 | 50 | M8 LOCK KNOB | 1 |
| 10 | LOWER CROSS BEAM | 1 | 51 | N/A | |
| 11 | CHEST PRESS BAR | 1 | 52 | HAND GRIPS | 4 |
| 12 | LEG EXTENSION UPRIGHT | 1 | 53 | 38mm SQUARE END CAPS | 29 |
| 13 | LEG EXTENSION | 1 | 54A | 38mm SQUARE OUTER CAPS | 5 |
| 14 | N/A | | 55 | 25mm ROUND END CAPS | 4 |
| 15 | LAT BAR | 1 | 56 | N/A | |
| 16 | SELECTOR SHAFT | 1 | 57 | 25mm ROUND OUTER CAP | 1 |
| 17 | FLOATING PULLEY BRACKET | 1 | 58 | SELECTOR SHAFT BUSH | 1 |
| 17A | AUXILIARY LEG PULLEY BRACKET | 1 | 59 | TOP WEIGHT PLATE | 1 |
| 18 | FOOT PLATE | 1 | 60 | STANDARD WEIGHT PLATES | 6 |
| 19 | FRONT STABILISER | 1 | 61 | END CAP SELECTOR SHAFT | 1 |
| 20 | REAR STABILISER | 1 | 62 | RUBBER BUMPERS | 2 |
| 21 | WEIGHT GUIDE TUBES | 2 | 63 | OIL BUSHING | 4 |
| 22 | BASE FRAME U BRACKET | 1 | 64 | N/A | |
| 23 | PAD BARS | 2 | 65 | PEC DECK FOAM PAD | 2 |
| 24 | AUXILIARY PEC PULLEY BRACKET | 1 | 66 | LEG EXTENSION FOAM PAD | 4 |
| 25 | M10 x 20mm HEX HEAD BOLTS | 2 | 67 | N/A | |
| 26 | M10 x 40mm HEX HEAD BOLTS | 5 | 68 | PULLEYS | 15 |
| 27 | M10 x 55mm HEX HEAD BOLTS | 17 | 69 | N/A | |
| 28 | M10 x 60mm HEX HEAD BOLTS | 4 | 70 | BACKREST | 1 |
| 29 | M10 x 65mm HEX HEAD BOLTS | 1 | 71 | SEAT BACK | 1 |
| 30 | N/A | | 72 | CHAIN | 1 |
| 31 | M10 x 80mm HEX HEAD BOLTS | 10 | 73 | M8 x 25mm HEX HEAD BOLTS | 1 |
| 32 | M10 x 130mm HEX HEAD BOLTS | 2 | 74 | M8 NYLON NUT | 1 |
| 33 | M8 x 55mm CARRIAGE BOLT | 1 | 75 | M10 x 38mm OD FLAT WASHERS | 10 |
| 34 | M8 x 50mm HEX HEAD BOLTS | 5 | | | |
| 35 | M10 NYLON NUTS | 41 | | | |
| 36 | M12 NYLON NUTS | 2 | | | |
| 37 | M12 WASHER FOR THE TOP PLATE | 1 | | | |
| 38 | M10 x 20mm OD FLAT WASHERS | 84 | | | |
| 39 | M8 FLAT WASHERS | 7 | | | |
| 40 | M12 FLAT WASHERS | 2 | | | |
| 41 | WEIGHT SELECTOR PIN | 1 | | | |
| 42 | BACKREST LOCK PIN | 1 | | | |
| 42A | PEC DECK ARM LOCK PINS | 2 | | | |

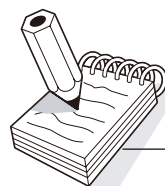

Note

Some of the above accessories are pre-fitted to the master component. They may not be supplied separately

V-FIT-ST



Beny Sports Co. UK Ltd.

*Unit 8 Riparian Way,
The Crossings Business Park,
Cross Hills,
West Yorkshire
BD20 7BW*

CUSTOMER SUPPORT

Open from 9.00am to 5.00pm from Monday to Friday



*Tel: **FREEPHONE** (in the UK) 0800 3 101 202
or
+44 (0) 1535 637711 (outside the UK)*



E-mail: support@benysports.co.uk



Website: www.benysports.co.uk

© Copyright BSCL - 2021