

SERIAL NO. DS2669-UK

V-fit



Tornado Air Rower

Assembly & User Manual

Please ensure that you read this manual carefully before attempting to use your new product and retain it for future reference

Contents

<i>Section</i>	<i>Page</i>
<i>General Information</i>	<i>4</i>
<i>Before You Start</i>	<i>5</i>
<i>Safety</i>	<i>6</i>
<i>Exercise Information</i>	<i>7</i>
<i>Assembly</i>	<i>14</i>
<i>Adjustments & Maintenance</i>	<i>23</i>
<i>Troubleshooting</i>	<i>25</i>
<i>Component Parts Lists</i>	<i>26</i>



Protect the environment by not disposing of this product with household waste.



General Information

Quality

This exercise product has been designed and manufactured to comply with the latest (BS EN 957) British and European Safety Standards.

Questions

Should you encounter any difficulty with the assembly, operation or use of your exercise product or if you think that you may have parts missing, please DO NOT return it to your retailer but contact us first for help and advice, asking for CUSTOMER SUPPORT, by any of the following means.

Tel:- 01535 637711 or

Fax:- 01535 637722 or

Email:- support@benysports.co.uk

Website: www.benysports.co.uk

CUSTOMER SUPPORT is open from 9.00am to 5.00pm from Monday to Friday

Beny Sports Co. UK Ltd.

Unit 8 Riparian Way,
The Crossings, Cross Hills,
West Yorkshire.
BD20 7BW

Queries

If you do have any queries, please ensure that you have the following information ready for our Customer Support Staff:

YOUR NAME

YOUR ADDRESS

YOUR PHONE NUMBER

PRODUCT MAKE OR BRAND

PRODUCT MODEL

PRODUCT SERIAL NUMBER

DATE OF PURCHASE

NAME OF RETAILER

PART NUMBERS REQUIRED

Guarantee

Beny Sports Co. UK Ltd. guarantee's its product range for DOMESTIC USE ONLY.

For specific guarantee periods please consult the Guarantee Registration Card supplied with your product.

During the Guarantee Period we have the right to: -

- provide parts for the purchaser to effect repair.
- repair the product returned (at the purchaser's cost) to our warehouse.
- replace the product if it is deemed economical to do so.

This guarantee applies to the original purchaser only and is not transferable.

This guarantee does not cover wear and tear on upholstery or consumables.

This guarantee does not cover abuse or defects caused by storage or use outside those intended.

If you need to advise us of a defect with your product, we will ask for proof of purchase. To enable us to service your requirement for replacement parts, you must return the enclosed Guarantee Registration Card within 14 days of purchase. Failure to do so will result in any claim for replacement parts or repairs being refused.

This does not affect your statutory rights as a consumer.

Customer Support

Tel:- 01535 637711 or

Fax:- 01535 637722 or

Email:- support@benysports.co.uk

Website: www.benysports.co.uk

CUSTOMER SUPPORT is open from 9.00am to 5.00pm from Monday to Friday

Beny Sports Co. UK Ltd.

Unit 8 Riparian Way,
The Crossings, Cross Hills,
West Yorkshire
BD20 7BW

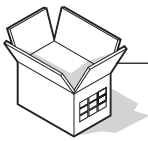

Before you Start

Tools

All products are supplied with basic tools, which will enable you to successfully assemble your product. However, you may find it beneficial to have a soft-headed hammer and perhaps an adjustable spanner handy as this may help.

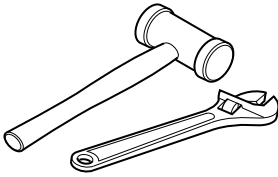

Prepare the Work Area

It is important that you assemble your product in a clean, clear, uncluttered area. This will enable you to move around the product while you are fitting components and will reduce the possibility of injury during assembly.

Work with a Friend

You may find it quicker, safer and easier to assemble this product with the help of a friend as some of the components may be large, heavy or awkward to handle alone.

Open the Carton.

Carefully open the carton that contains your product, taking note of the warnings printed on the carton to ensure that the risk of injury is reduced. Be aware of sharp staples that may be used to fasten the flaps as these may cause injury. Be sure to open the carton the right way up, as this will be the easiest and safest way to remove all the components.

Unpack the Components

Carefully unpack each component, checking against the parts list that you have all the necessary parts to complete the assembly of your product.

Please note that some of the parts may be pre-fitted to major components, so please check carefully before contacting our CUSTOMER SUPPORT team.

In any event, please do not return the product to your retailer before contacting us first.



Safety

Before you undertake any programme of exercise that will increase cardiovascular activity please be sure to consult with your doctor. Frequent strenuous exercise should be approved by your doctor and proper use of your product is essential. Please read this manual carefully before commencing assembly of your product or starting to exercise.

- * Please keep all children away from exercise products when in use. Do not allow children to climb or play on them when they are not in use. If children are allowed to use the equipment, their mental and physical development and above all their temperament should be taken into account. They should be controlled and instructed to the correct use of the equipment. The equipment is under no circumstances suitable as a children's toy.*
- * For your own safety, always ensure that there is at least 1 Metre of free space in all directions around your product while you are exercising.*
- * Regularly check to see that all nuts, bolts and fittings are securely tightened. Periodically check all moving parts for obvious signs of wear or damage.*
- * Clean only with a damp cloth, do not use solvent cleaners. If you are in any doubt, do not use your product, but contact CUSTOMER SUPPORT by any of the means listed on the opposite page.*
- * Before use, always ensure that your product is positioned on a solid, flat surface. If necessary, use a rubber mat underneath to reduce the possibility of damaging flooring or slipping in use.*
- * Always wear appropriate clothing and footwear such as training shoes when exercising. Do not wear loose clothing that could become caught or trapped during exercise.*
- * Parents and others in charge of children should be aware of their responsibility because the natural play instinct and the fondness of experimenting of children can lead to situations and behavior for which the training equipment is not intended.*



Warning

If any part of your product becomes damaged, broken or badly worn do not use the equipment until the defective parts have been replaced

Storage and Use

Your product is intended for use in clean dry conditions. You should avoid storage in excessively cold or damp places as this may lead to corrosion and other related problems that are outside our control.

Weight Limit

*Your product is suitable for users weighing:
253 LBS / 18 Stones / 115 KG or less.*

Conformity

*This product conforms to:
BS EN ISO 20957-1 and BS EN 957-7- HOME USE - Class (HC).
It is NOT suitable for therapeutic purposes.*



Exercising Information

Beginning

*How you begin to exercise will vary from person to person. If you have not exercised for a long period of time, have been inactive for a while, or are severely overweight you **MUST** start slowly, increasing your exercise time gradually, by perhaps only a few minutes for each session per week.*

Combine a carefully structured nutritious diet with a simple but effective exercise routine and this can help make you feel better, look better and will almost certainly enable you to enjoy life more.

Aerobic Fitness

Aerobic exercise is simply defined as any sustained activity that increases the supply of oxygen to your muscles via the blood pumped by your heart. With regular exercise, your cardiovascular system will become stronger and more efficient. Your recovery rate i.e. the time taken for your heart to reach its normal resting level, will also decrease.

Initially you may only be able to exercise for a few minutes each day. Do not hesitate to breathe through your mouth should you need more oxygen. Use the "talk test". If you cannot carry on a conversation while exercising, you are working too hard! However, aerobic fitness will be gradually built up with regular exercise, over the next six to eight weeks.

Do not be discouraged if it takes longer than this to begin to feel less lethargic, everyone is different and some will achieve their targets quicker than others. Work at your own, comfortable pace and the results will come. The better your aerobic fitness the harder you will have to work to stay in your target zone.



Exercising Information

Warm Up

A successful exercise programme consists of three parts, Warm Up, Aerobic Exercise and Cool Down. Never start a training session without warming up. Never finish one without cooling down correctly. Perform between five and ten minutes of stretching before starting your workout to prevent muscle strains, pulls and cramps.

Aerobic Exercise Session

Those new to exercise should exercise no more than every other day to start with.

As your fitness level increases, increase this to 2 in every 3 days.

When you are comfortable with your routine, exercise for 6 days per week. Always take at least one day off per week.



Note

Incorrect or excessive training may damage your health. Please read the exercise information first.

Exercising in your Target Zone

To ensure that your heart is working in its exercise target zone, you need to be able to take your pulse. If you do not have a pulse monitor (either from the product you are using or a proprietary independent unit) you will need to locate the pulse in your carotid artery. This is situated in the side of the neck and can be felt by using the index and middle fingers. Simply count the number of beats you feel in 10 seconds and then multiply by six to get your pulse rate. This should be taken before you start to exercise for easy reference.

People who have a greater aerobic fitness, have a lower resting pulse level and will also be able to exercise with a higher pulse level.

Target Zone

To determine your target zone, see the chart opposite. If you are new to exercise and by definition unfit, refer to the left column. If you exercise regularly and have good aerobic fitness, refer to the right column.



Exercising Information

Target Zone (con't)

USERS AGE	UNCONDITIONED TARGET ZONE - A	CONDITIONED TARGET ZONE - B
(Years)	(Beats per Minute)	(Beats per Minute)
20-24	145 - 165	155 - 175
25-29	140 - 160	150 - 170
30-34	135 - 155	145 - 165
35-39	130 - 150	140 - 160
40-44	125 - 145	135 - 155
45-49	120 - 140	130 - 150
50-54	115 - 135	125 - 145
55-59	110 - 130	120 - 140
60 and over	105 - 125	115 - 135

Cool Down

To decrease fatigue and muscle soreness, you should also cool down by walking at a slow relaxed pace for a minute or so, to allow your heart rate to return to normal.

Warm Up and Cool Down Exercises

Hold each stretch for a minimum of ten seconds and then relax. Repeat each stretch two or three times. Do this before your Aerobic Exercise session and also after you have finished.

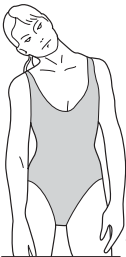

Head Roll

Rotate your head to the right for one count, feeling a slight pull on the left side of your neck. Next, rotate your head back for one count, stretching your chin. Then rotate your head to the left for one count, feeling a slight pull on the right side of your neck. Lastly, drop your head to your chest for one count. Repeat 2 to 3 times.

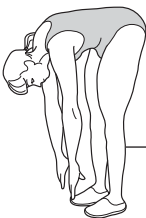

Toe Touch

Slowly bend forward from your waist, letting your back and shoulders relax as you lower your trunk. Gently stretch down as far as is comfortable and hold for 10 seconds.



Exercising Information



Shoulder Lift

Rotate and lift your right shoulder up towards your ear for one count. Relax then repeat for the left shoulder. Repeat 3 - 4 times.

Calf / Achilles Stretch

Turn towards the wall and place both hands on it. Support yourself with one leg while the other is placed behind you with the sole flat on the floor. Bend the front leg and lean towards the wall, keeping the rear leg straight so that the calf and Achilles tendon are stretched hold for 5 seconds. Repeat with the other leg. Repeat 2 - 3 times.

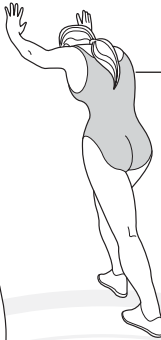

Side Stretch

Open both arms to the side and gently lift them above your head. Reach your right arm as high as you can for one count, gently stretching the muscles of the stomach and lower back. Repeat the action with your left arm. Repeat 3 - 4 times.

Inner Thigh Stretch

Sit on the floor and pull your legs toward your groin, the soles of your feet together. Hold your back straight and lean forward over your feet. Tighten the thigh muscles and hold for 5 seconds. Release and repeat 3 - 4 times.



Hamstring Stretch

Sit on the floor with your right leg extended and place your left foot flat against the right inner thigh. Stretch forward toward the right foot and hold for 10 seconds. Relax and then repeat with the left leg extended. Repeat 2 - 3 times.

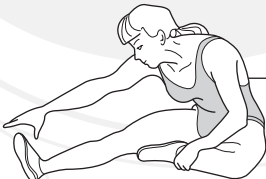



Exercising Information

Basic Aerobic Training Programme

For your basic Aerobic Exercise routine we suggest that you try the following. Remember, breathe correctly, exercise at your own pace and do not over-train as injury may result.

Week 1 & 2

Warm Up 5 - 10 Minutes
Cool Down 5 Minutes

Exercise 4 minutes at 'A'
Rest 1 minute
Exercise 2 minutes at 'A'
Exercise slowly 1 minute

Week 3 & 4

Warm Up 5 - 10 Minutes
Cool Down 5 Minutes

Exercise 5 minutes at 'A'
Rest 1 minute
Exercise 3 minutes at 'A'
Exercise slowly 2 minutes

Week 5 & 6

Warm Up 5 - 10 Minutes
Cool Down 5 Minutes

Exercise 6 minutes at 'A'
Rest 1 minute
Exercise 4 minutes at 'A'
Exercise slowly 3 minutes

Week 7 & 8

Warm Up 5 - 10 Minutes
Cool Down 5 Minutes

Exercise 5 minutes at 'A'
Exercise 3 minutes at 'B'
Exercise 2 minutes at 'A'
Exercise slowly 1 minute
Exercise 4 minutes at 'A'
Exercise slowly 3 minutes

Week 9 & beyond

Warm Up 5 - 10 Minutes
Cool Down 5 Minutes

Exercise 5 minutes at 'A'
Exercise 3 minutes at 'B'
Exercise 2 minutes at 'A'
Exercise slowly 1 minute
Repeat entire cycle 2 or 3 times

This is only a suggested programme and may not suit every individual's needs.



Exercising Information

EXERCISING WITH YOUR AIR ROWER

It is possible to use your Air Rower in two different ways, to increase cardiovascular fitness and create lower body / upper body leg and arm strength.

AEROBIC WORKOUT (Pull hard-faster pace)

It is not possible to manually increase or decrease the rowing resistance for aerobic workouts on your Air Rower in order to build cardiovascular fitness. However, the Rowing-Arm strength increases proportionately with the rowing speed and effort. e.g. the harder or quicker you row, the more resistance, or drag is created by the Air Fan. With all aerobic exercise, you should exercise at a constant, reasonable pace when warmed up. (See the section about Warm-Up and Target Heart Rate Training elsewhere in this booklet). The aerobic benefit of the exercise will increase as the rowing rate increases and your cardio-vascular fitness will benefit as a result. The muscles in the legs, thighs, arms and lower back will also be strengthened by the rowing action.

STRENGTH WORKOUT (Pull hard-slower pace)

As with the Aerobic Workout, it is not possible to directly increase the rowing resistance for a full strength workout on your Air Rower in order to build muscle strength. However, if you increase your Rowing-Arm strength in order to generate more drag on the air fan, the exercise resistance will increase, allowing the muscles in the legs, thighs, arms and lower back to be strengthened by the rowing action. Your cardio-vascular fitness will, with time, also benefit.

EXERCISE MONITOR FUNCTIONS

With your Air Rower the 3 screen, 6 function Exercise Monitor is set to start automatically when you begin to row. However, it is possible to switch on the monitor by pressing the Page Change Button at the bottom of the monitor. To save battery consumption, the monitor will also switch off after it has been idle for approximately four minutes.

Please refer to the leaflet supplied with the Exercise Monitor for all operational functions.

Exercising Information



Note

Incorrect or excessive training may damage your health. Please read the exercise information first.

FIG. 1

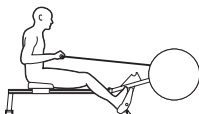
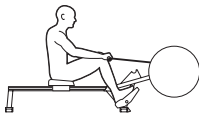

EXERCISE No. 1

THE COMPLETE ROWING ACTION

This exercise will help tone and strengthen the muscle groups in your legs, arms, shoulders, back and stomach.

Start as shown in Fig. 1 with the rowing-grip fully 'home'. Slide down on the seat, knees bent and grasp the rowing-grip.

Slowly move backwards, keeping a straight back, extending the legs and pulling the rowing-grip towards your chest.

Return to the start position and repeat.

FIG. 4



EXERCISE No. 2

ARMS ONLY ROWING

This exercise will help isolate the muscles in your arms, shoulders, back and stomach.

Start as shown in Fig. 4 with your legs straight. Lean forward and grasp the rowing-grip. In a gradual and controlled manner, return to the fully upright position, curling, (overhand grip for Triceps muscle exercise) or pulling, (underhand grip for Biceps muscle exercise) the rowing-grip towards the chest until fully extended.

Return to the start position and repeat.

FIG. 7



EXERCISE No. 3

LEGS ONLY ROWING

This exercise will help tone and strengthen the muscles in your legs and back.

Start as shown in Fig. 7 with your back straight and arms outstretched. Slide down on the seat, knees bent and grasp the rowing-grip.

Extending your legs only and ensuring that you keep your back and arms straight, push your body back toward the end of the rower main rail. Return to the start position and repeat.

Assembly



ACCESSORY FITMENT LIST

These are all the accessories you will need to complete the assembly of your product.

The following accessories are loosely assembled to the frame or master component and will need to be removed prior to assembly

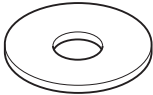

Item 51
Qty 2



Item 18
Qty 2



Item 48
Qty 2



Item 46
Qty 2



Item 47
Qty 2

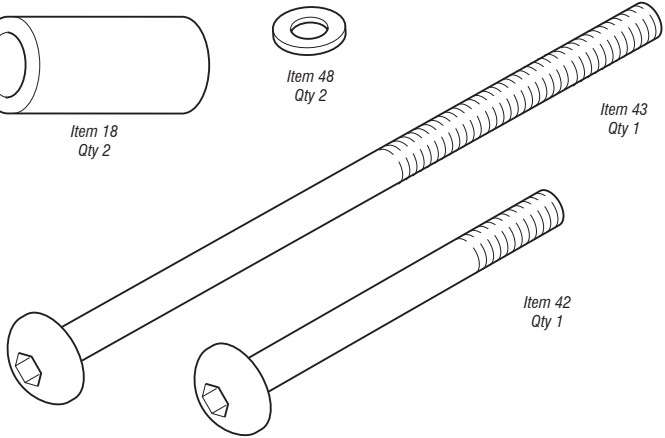

Item 42
Qty 1

Item 43
Qty 1

The following accessories are supplied in a pack and should be checked before attempting assembly

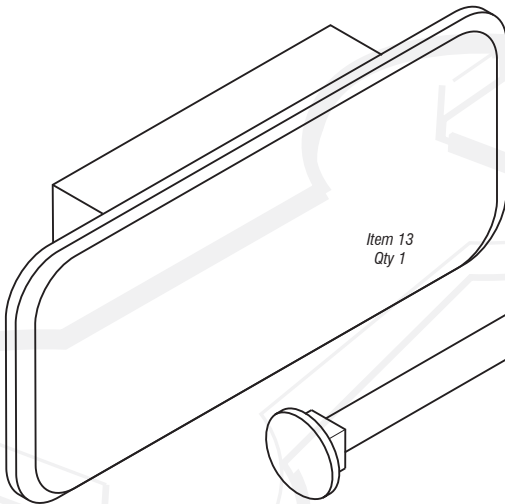

Item 13
Qty 1

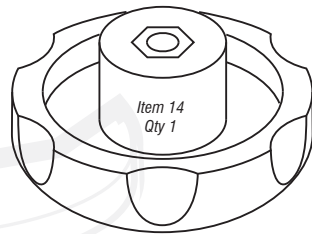

Item 14
Qty 1

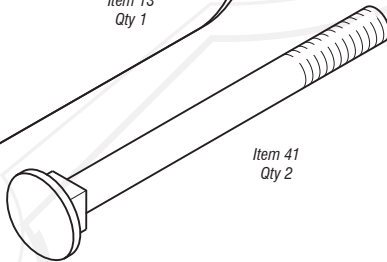

Item 41
Qty 2



Item 44
Qty 3



Item 50
Qty 2



Item 48
Qty 2



Item 53
Qty 2



Item 45
Qty 2



Item 49
Qty 2

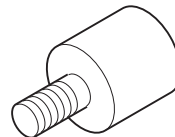

Item 11
Qty 2

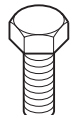

Item 40
Qty 1

Assembly



Beny Sports Co. UK Ltd
Unit 8 Riparian Way,
The Crossings, Cross Hills,
West Yorkshire.
BD 20 7BW

Carefully unpack each component, checking against the parts list that you have all the necessary parts to complete the assembly of your product.

PLEASE NOTE that some of the parts may be pre-fitted to major components, so please check carefully before contacting our CUSTOMER SUPPORT team.

In any event, please do not return the product to your retailer before contacting us first.

Tel:- 01535 637711 or

Fax:- 01535 637722 or

E-mail:- support@benysports.co.uk

CUSTOMER SUPPORT is open from 9.00am to 5.00pm from Monday to Friday.

- 1 The Main Frame (1) of your Air Rower should look as below when removed from the carton.

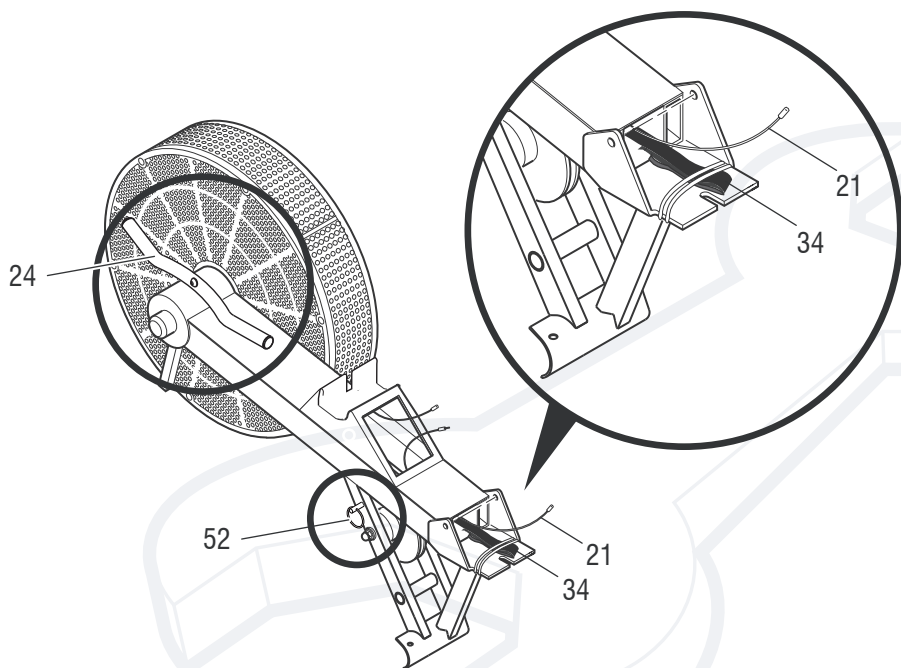

Assembly



2 Securely attach the Front Frame Stabiliser (3) to the Main Frame (1) with 2 x M8 x 75mm Carriage Bolts (41) 2 x M8 Curved Washers (53) 2 x M8 Spring Washers (50) and 2 x M8 Dome Nuts (45). Tighten fully.

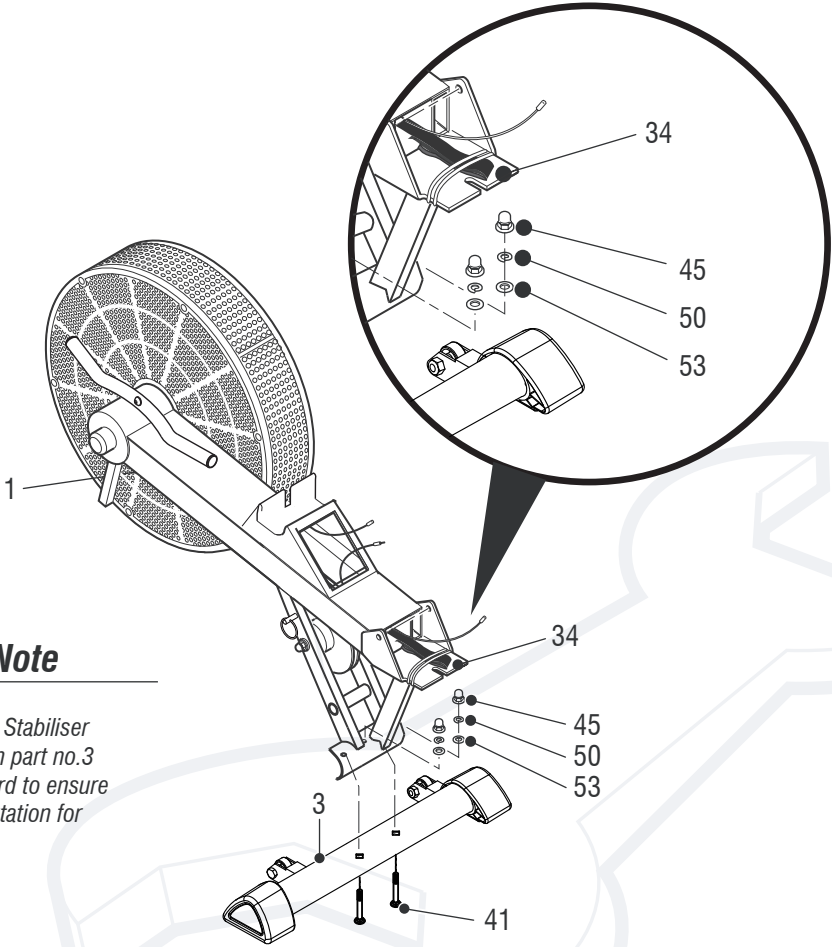

Note

The Front Frame Stabiliser Roller Wheels on part no.3 must face forward to ensure ease of transportation for storage.

Assembly



- 3** Connect the front end of the Rowing Rail (2) to the Rowing Rail Pivot Bracket (12) on top of the Main Frame with 1 x M8 x 135mm Allen Bolt (43), 1 x M8 Small OD Flat Washer (48) and 1 x M8 Nylon Locknut (46). Carefully lift the Rowing Rail over the top of the Main Frame and let it rest onto the Exercise Monitor Console (20).

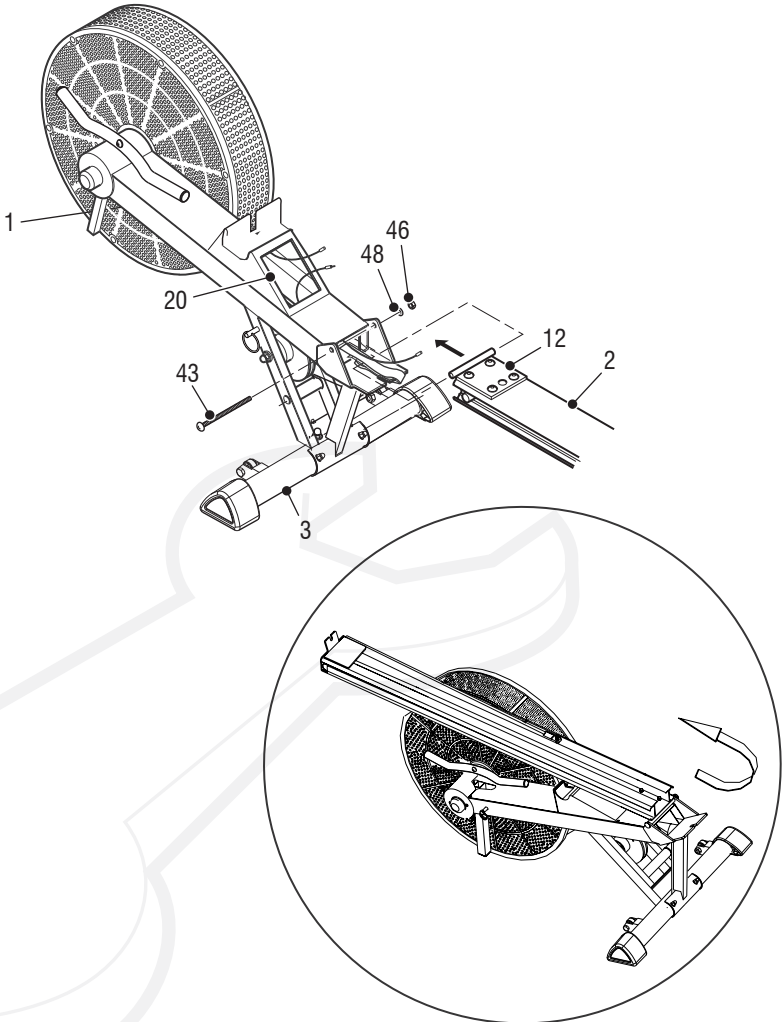

Assembly



- 4** This operation is best carried out with 2 people.
Remove the Elastic Band from the Drive Strap (34) and extend the Drive Strap (34) up the Rowing Rail to where the Return Cord (36) is held. Disconnect the Carabina Clip (35) on the end of the Return Cord (36) from its transportation location at the back of the Rowing Rail and connect the Return Cord and Drive Strap together as Fig A

Connect the Exercise Monitor Link Cable (21) to the Seat Sensor Cable (22) ensuring that the contacts are pushed fully home. (You will hear / feel 2 clicks indicating that correct contact has been made). (See Fig B)

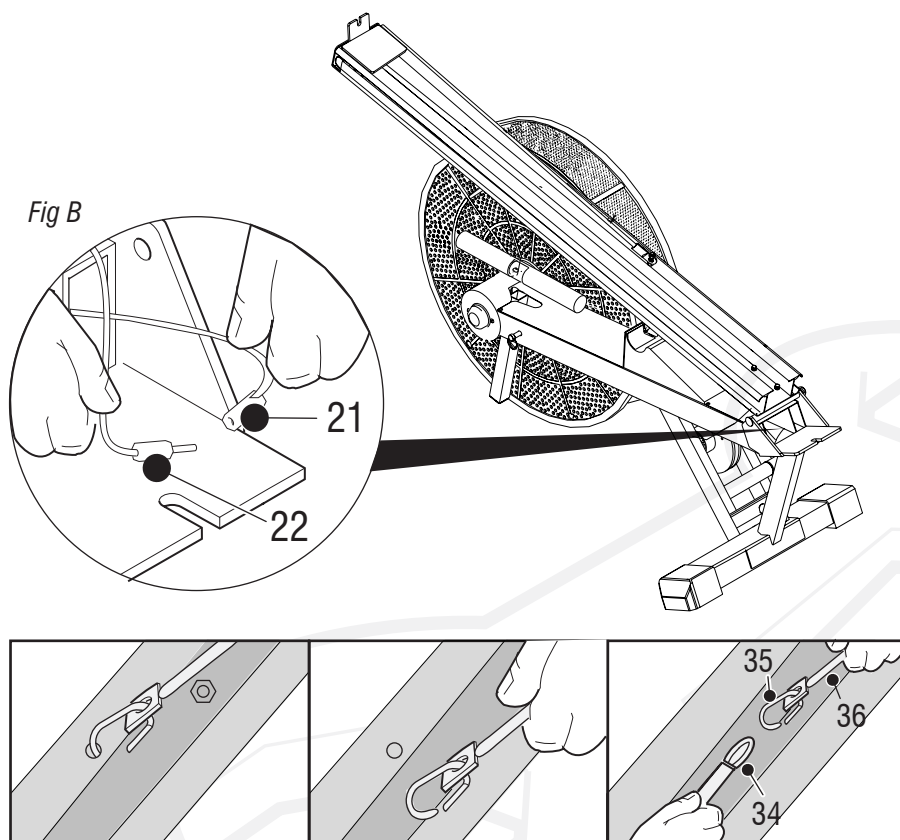

Fig A

Assembly



- 5** Attach the Rear Frame Stabiliser (4) to the underside of the Rowing Rail (2) using 1 x M8 x 70mm Allen Bolt (42), 1 x M8 Small OD Flat Washer (48) and 1 x M8 Nylon Locknut (46).

Secure this in place by tightly fitting the Rear Stabiliser Knob (7).

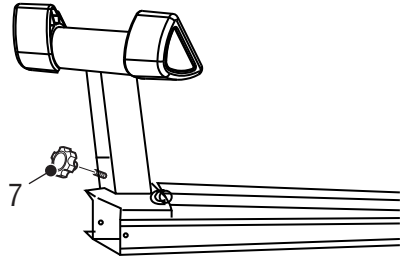
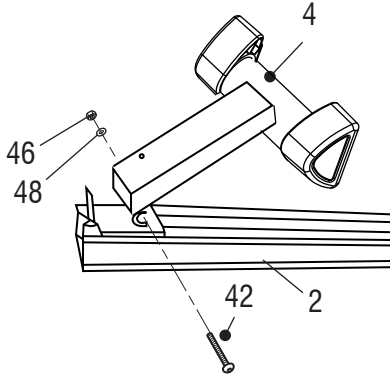

- 6** Rotate the Rowing Rail back over to its in-use position and secure Rowing Rail (2) in place with 1 x M8 Large OD Flat Washer (49) and the Rowing Rail Pivot Knob (14), tightening securely.
Note: - It is imperative that the Large OD Flat Washer is fitted before using your Air Rower.

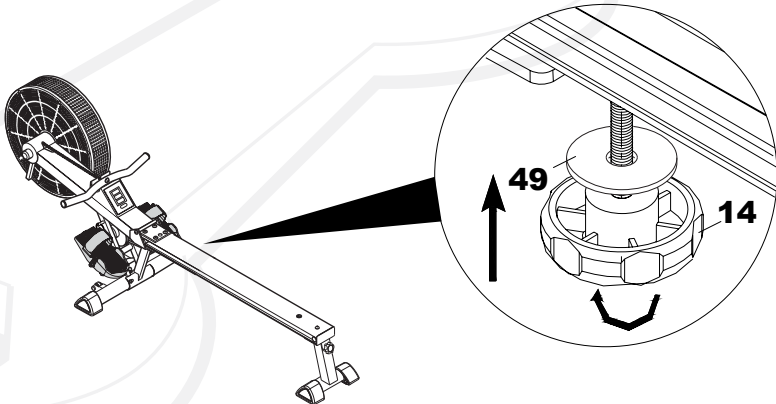

Assembly



7

Slide the assembled Seat Carriage (9) onto the Rowing Rail (2) from the back and fit a Seat Carriage Stop Assembly (11) to each side of the Rail with the 2 x M8 Small OD Flat Washers (48) and 2 x M8 Plain Nuts (44) which should be fitted on the inside of the rail. Cap the end with the Rowing Rail End Cap (13).



Note

Compliance to BS EN 957 requires that an additional / alternative seat stop to be fitted. If desired, please fit the 1 x M8 x 20mm Hex Bolt (40) and 1 x M8 Large OD Flat Washer (49) in the hole on the top of the Rowing Rail and secure in place from the underside using 1 x M8 Plain Nut (44). A hard rubber buffer is pre-fitted to the underside of the Seat Carriage (9) to act as a stop.

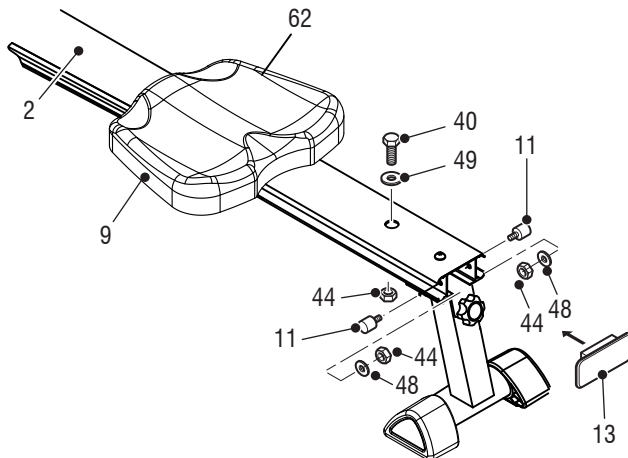

8

For your convenience, the Velcro style adjustable Footplate Straps (16) are pre-fitted to the Footplates (15) in the lower of the 2 positioning options. Slide the Footplate Crossbar (17) into the Main Frame and then slide a Footplate Crossbar Spacer (18) onto each end of the bar, followed by a Footplate, securing in place with 2 x M10 Large OD Flat Washers (51) and 2 x M10 Nylon Locknuts (47).

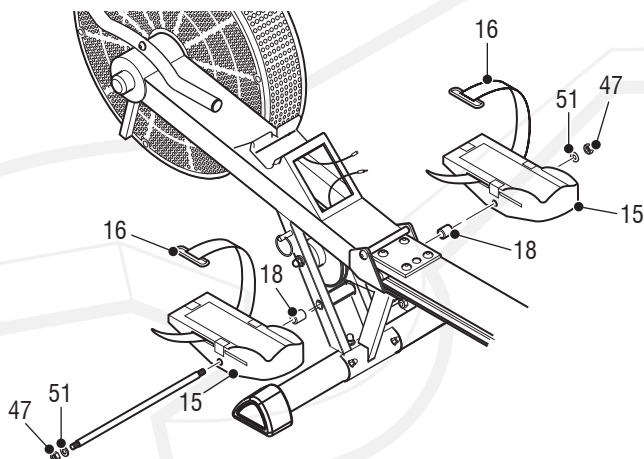

Assembly



9

Fit 2 x AA Batteries (not supplied) to the battery carrier in the Exercise Monitor (19) then connect the Air Fan Sensor Cable (23) to the MALE plug in the rear of the Monitor and the Exercise Monitor Link Cable (21) to the FEMALE plug ensuring that the contacts are pushed fully home. (You will hear / feel 2 clicks indicating that correct contact has been made). Guide the spare length of the Air Fan Sensor Cable into the exit cutout in the Main Frame then carefully push the complete Exercise Monitor (19) into place in the top of the Monitor Console (20).

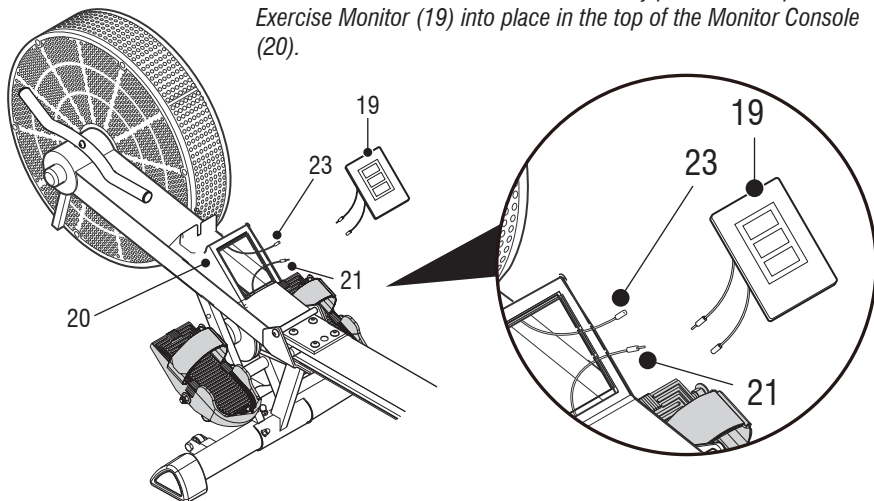

10

1. Remove the Lock Pin (52) from the Main Frame and retain for future use to lock the drive if needed for maintenance or transportation. **DO NOT** refit when in regular use.

2. Carefully pull the Row Bar (24) back and set it in its rest position on top of the Exercise Monitor Console (20).



Note

FULLY TIGHTEN all Bolts, Nuts and Fittings now, ensuring that your Air Rower is located on a clear flat surface before doing so. Your Air Rower will now be ready to use.

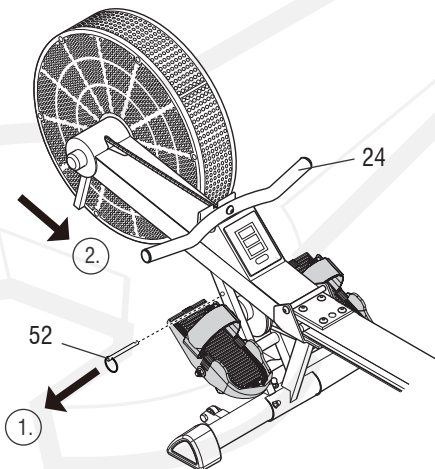

Assembly

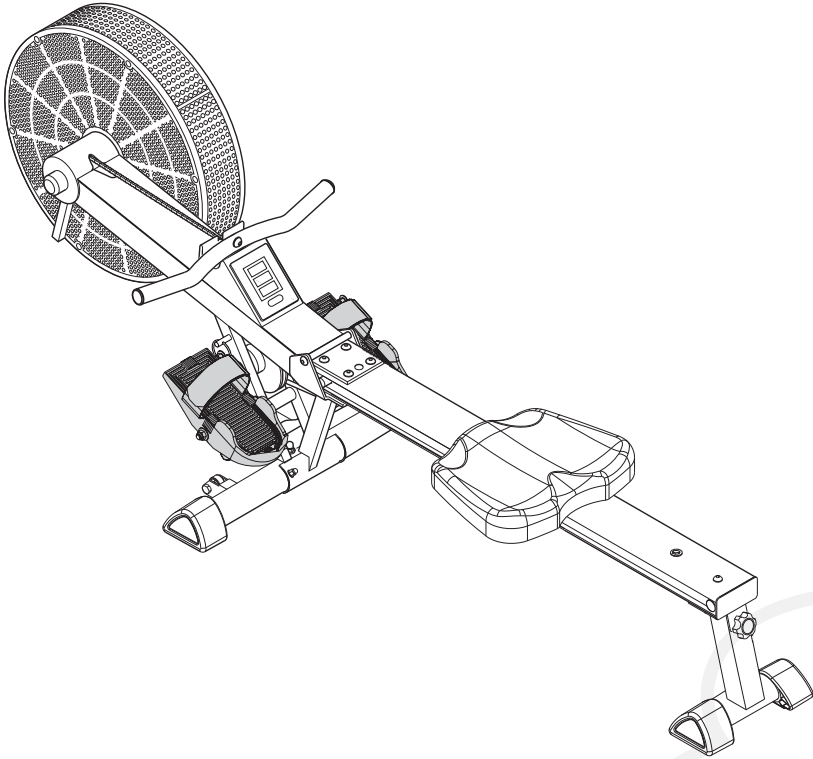

Note

We suggest using a rubber mat under the Air Rower to add stability in use and to help protect floor coverings.

Adjustments & Maintenance



Note

There is no other way of increasing rowing resistance during your exercise routine, but please bear in mind that rowing is essentially an aerobic exercise.



Note

When you have finished your routine, be sure to set the Row Grip in its rest on top of the Exercise Monitor Console.



Note

In the interest of safety, do NOT use polish or any lubricant on the seat, foam handgrips or footplates.

OPERATING ADJUSTMENTS and GENERAL USER INFORMATION

LEVELLING THE AIR ROWER

For security and stability, your Air Rower has a factory welded main frame and once fully assembled correctly, should not need further alignment. However, in the interest of safety, please always ensure that your Air Rower is positioned on a solid, flat surface. If necessary, use a rubber mat underneath to reduce the possibility of damaging flooring or slipping in use.

ABOUT YOUR ROWER

Your Air Rower does not have a user applied resistance adjustment. However, to ensure smooth efficient rowing action, your Air Rower applies its resistance by the action of the fully enclosed air fan on air drawn into the air fan cover. The resistance on the Air Rower is classified as Speed Dependant. The harder / faster you row, greater resistance is generated.

MAINTENANCE

At least weekly check the lower channel in the Rowing Rail on both sides for build-up of dust or other debris. Make sure this is regularly cleaned with a soft damp cloth.

Adjustments & Maintenance



FOLDING THE ROWER FOR STORAGE

1. Slide the Seat forwards then unscrew and remove the Rowing Rail Pivot Knob (14) and the Large OD Flat Washer (

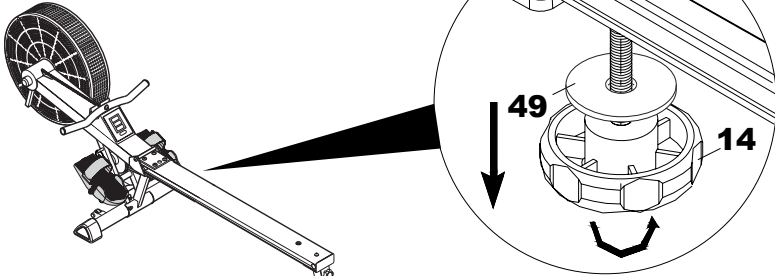

2. Carefully rotate the Rail up and over the top of the Main Frame. Lower gently so the Seat is positioned above the Exercise Monitor and its Console.
Note: - The Front of the Rower will tip forward to rest on the floor.

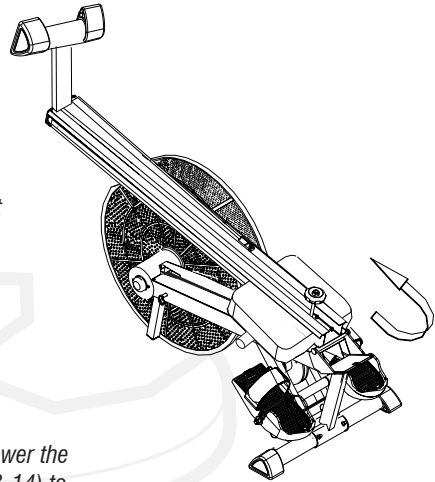

3. Unscrew the Rear Stabiliser Knob (7) and carefully lower the Stabiliser onto the Rowing Rail. Refit both Knobs (7 & 14) to ensure safe keeping.

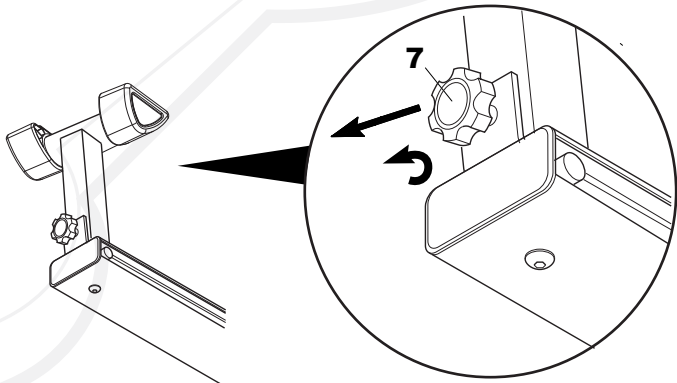



Troubleshooting Guide

Monitor is set to Kilometres and needs changing to Miles

Remove one of the Monitor's AA Batteries and wait for 30 seconds. Refit the Battery while holding down the Reset Button and press again to set either M or K in the left corner of the centre screen.

Feet are sliding out of the Footplates in use

The Footstraps (16) on your Air Rower can be set to two different positions. Slide the Foot-straps out of the guides in the Footplates (15) and refit using the lower set of holes in the Footplates. This will ensure that your ankles are pulled tightly into the Footplate and will reduce the possibility of slipping in use.

There does not appear to be any “drive” to the Air Fan

The Drive Chain (31) has come off the Drive Gear Spindle (32) at the front of the Air Rower. Remove the 2 x M5 x 12mm Machine Screws (39) that are securing the Drive Gear Cover (33) and pull it towards you. Facing the Air Rower from the side with the Air Fan (27) on the left and the Seat (8) on the right, with your LEFT hand, lift the Row Arm (24) vertically and with your right hand underneath the Main Frame (1) pull the Drive Chain from right to left so that you can carefully feed the Drive Chain back onto the Drive Gear Spindle at the front of the Air Rower. When secured, slowly lower the Row Arm into its storage location at the top of the Exercise Monitor Console (20).

The Stokes per Minute Counter does not work

First, check the above step regarding Drive to Fanwheel. If this does not work then check and remake the connections between all of the Sensor Cables (21, 22, and 23). Fold the Rowing Rail (2) over the top of the Main Frame (see Page 24 for Folding Instructions) and slightly rotate the Seat Sensor (22) about its fitting screw and then move the Seat (8) up and down to check if the Exercise Monitor (19) responds. Continue to move until the Monitor indicates a Stroke Count or SPM figure.

The Speed Counter does not work

Unscrew the 6 (3 inside, 3 outside) x M4 x 63mm S/T Screws holding the Fan Covers (28) together. Remove the Outer Fan Cover and the 4 x Air Fan Cover Inserts (29). Check to see if the Air Fan Magnet is still in place in its location in a recess towards the centre of the Air Fan. If it is secure, rotate the tip of the Air Fan Sensor Cable (23) about its fixing point until spinning the Air Fan (27) causes the Exercise Monitor to register.

The Seat “bumps” when in use

Make sure that the lower part of the Rowing Rail (2) is always kept clean and dust / debris free as dust will become compacted and as a consequence damage the Rail and the Seat Carriage Wheel Assemblies (10). Clean the groove with a clean damp cloth and if necessary remove the complete Seat Assembly and clean each Wheel before refitting.

Component Parts Lists

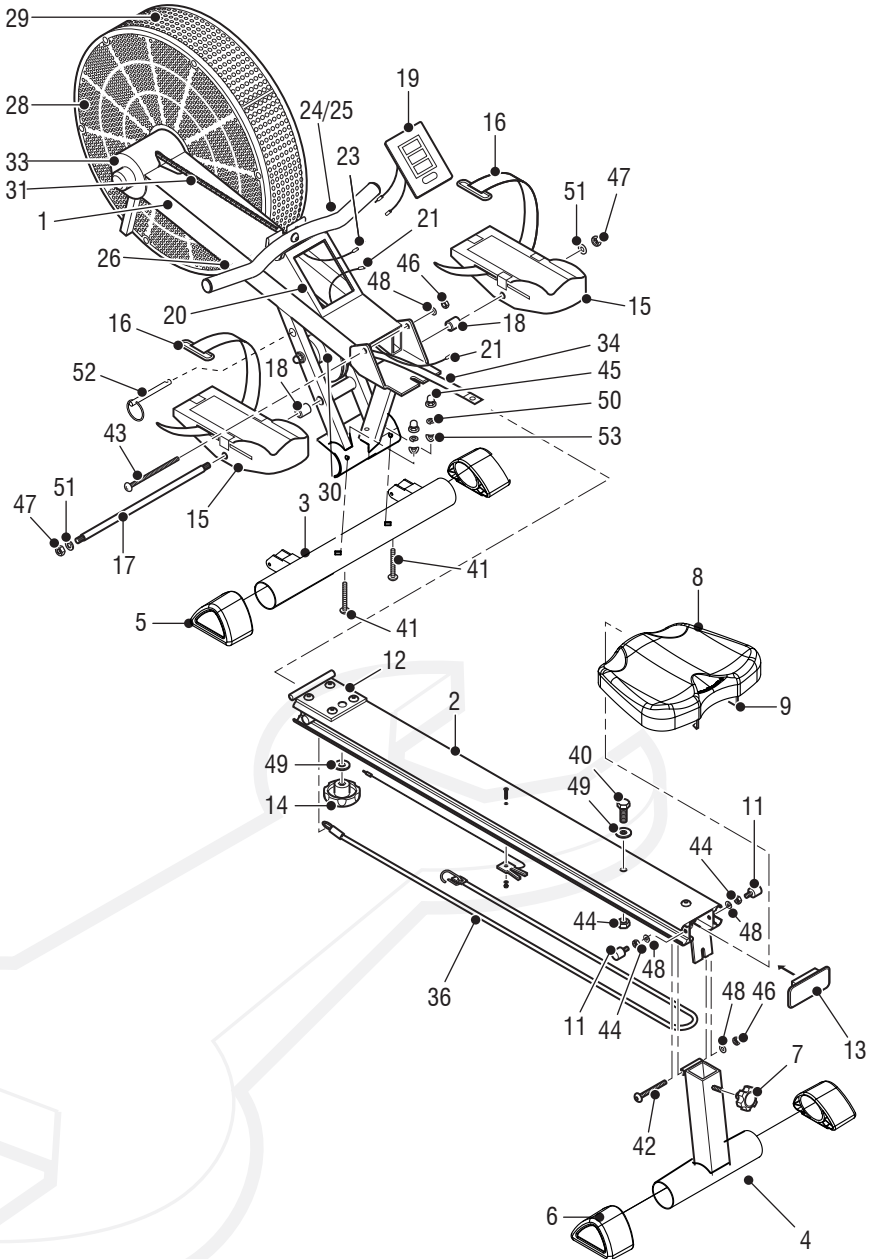



Component Parts Lists

MASTER PARTS & ACCESSORY LIST

PART No.	DESCRIPTION	QTY
1	MAIN FRAME	1
2	ROWING RAIL	1
3	FRONT FRAME STABILISER	1
4	REAR FRAME STABILISER	1
5	FRONT STABILISER ROLLER CAP	2
6	REAR STABILISER CAP	2
7	REAR STABILISER KNOB	1
8	SEAT	1
9	SEAT CARRIAGE	1
10	SEAT CARRIAGE WHEEL ASSY	6
11	SEAT CARRIAGE STOP ASSY	3
12	ROWING RAIL PIVOT BRACKET	1
13	ROWING RAIL END CAP	1
14	ROWING RAIL PIVOT KNOB	1
15	FOOTPLATE	2
16	FOOTPLATE STRAP	2
17	FOOTPLATE CROSSBAR	1
18	FOOTPLATE CROSSBAR SPACER	2
19	EXERCISE MONITOR	1
20	EXERCISE MONITOR CONSOLE	1
21	EXERCISE MONITOR LINK CABLE	1
22	SEAT SENSOR CABLE	1
23	AIR FAN SENSOR CABLE	1
24	ROW ARM	1
25	ROW ARM HANDGRIP	1
26	ROW ARM END CAP	2
27	AIR FAN ASSEMBLY	1
28	AIR FAN COVER (INNER & OUTER)	2
29	AIR FAN COVER INSERT	4
30	DRIVE WHEEL	1
31	DRIVE CHAIN	1
32	DRIVE GEAR SPINDLE	1
33	DRIVE GEAR COVER	1
34	DRIVE STRAP	1
35	CARABINA CLIP	1
36	RETURN CORD	1
37	RETURN CORD PULLEY	1
38	M4 x 63mm S/T SCREW	6
39	M5 x 12mm MACHINE SCREW	2
40	M8 x 20mm HEX BOLT	1
41	M8 x 75mm CARRIAGE BOLT	2
42	M8 x 70mm ALLEN BOLT	1
43	M8 x 135mm ALLEN BOLT	1
44	M8 PLAIN NUT	4
45	M8 DOME NUT	2
46	M8 NYLON LOCKNUT	10
47	M10 NYLON LOCKNUT	2
48	M8 SMALL OD FLAT WASHER	4
49	M8 LARGE OD FLAT WASHER	2
50	M8 SPRING WASHER	2
51	M10 LARGE OD FLAT WASHER	2
52	LOCK PIN	1
53	M8 CURVED WASHER	2



Note

The majority of the above parts will have been pre-fitted to the master part or component. Please check carefully as they may NOT be supplied separately.

V-fit



Beny Sports Co. UK Ltd.

*Unit 8, Riparian Way,
The Crossings, Cross Hills,
West Yorkshire
BD20 7BW*

CUSTOMER SUPPORT

is open from 9.00am to 5.00pm from Monday to Friday



Tel: 01535 637711



Fax: 01535 637722



E-mail: support@benysports.co.uk



Website: www.benysports.co.uk